

## SYSTEMATIC DESIGN OF A STRAIN GAUGE CALIBRATION DEVICE FOR WAYSIDE MEASUREMENT SYSTEMS

**Abdullah Çelik, Muzaffer Metin**

Department of Mechanical Engineering, Faculty of Mechanical Engineering, Yıldız Technical University, Barbaros Blvd., 34349 İstanbul, Türkiye (✉ [mmetin@yildiz.edu.tr](mailto:mmetin@yildiz.edu.tr))

### Abstract

Wayside measurements by means of strain gauge placed on rails are an important test method to measure the wheel-rail contact forces that determine the safety of rail vehicles traveling on the track. In this method, to enhance the reliability of the monitoring results, strain gauge sections and measurement equipment should be calibrated under operating conditions. In this study, a design of a device has been developed for the calibration of strain gauges used in wayside measurement techniques. The systematic approach proposed by Pahl and Beitz and further developed by Feldhusen and Grote was utilized in the design process. With this innovative design, a safe, simple, compact, and user-friendly device capable of applying both vertical and horizontal forces with a single unit has been developed.

**Keywords:** wheel-rail contact force, wayside measurement, calibration device, systematic design.

### 1. Introduction

Wheel-rail contact forces are a critical factor in the performance of railway vehicles. These forces originate from the interaction between the wheels and rails and are transmitted through the vehicle's suspension system to the bogie and vehicle body. Wheel-rail forces influence ride quality, wheel wear, and derailment safety. Therefore, measuring these forces is of significant importance, and consequently, methods [1] have been developed to measure wheel-rail contact forces. These methods can be divided into two main categories: vehicleside (on-board) method [2-6] and wayside (ground) method [7-11].

The vehicleside method is based on the direct measurement of strains using a specially *instrumented wheelset* (IWS). This approach enables measurements to be taken across the entire railway network with a single vehicle. The wayside method involves directly testing the response of rail components by placing sensors on the rail. The measurement principle typically relies on the use of strain gauges to measure rail strains. This method is used to measure contact forces on a relatively short rail section from all vehicles passing through the measurement area. The European Standard [12] does not recommend a specific method for measuring contact forces. The vehicleside method has disadvantages such as the need for specialized knowledge, the requirement for specially designed wheelsets depending on the type of vehicle, the inability to quickly address malfunctions, and the high costs of manufacturing, calibration, maintenance, and operation. In contrast, the wayside method is easier and faster to calibrate and transfer to the test area, and it is more cost-effective.

In the wayside method, strain gauge sections and measuring equipment are calibrated to improve the reliability of monitoring results under operating conditions. The calibration process is critical to ensure the accuracy and precision of the sensors [13]. Calibration methods can be applied statically or dynamically depending on predetermined forces. Calibration systems in

the literature are generally schematized in Fig. 1 [14]. The system where a hydraulic or mechanical jack is placed between a rail and a load wagon with a known weight to calibrate the strain gauge unit is illustrated in Fig. 1a. The portable extension device for calibrating the strain gauge unit, which is fixed on both sides of the rail, with a hydraulic or mechanical jack placed between the upper support and the rail, and static forces measured using an electric dynamometer, is shown in Fig. 1b. The calibration method involving a known-weight impact device dropped from a height onto the rail, with timing parameters recorded to determine the impact force indirectly, is illustrated in Fig. 1c. The systems shown in Fig. 1 are designed to measure strains caused by vertical forces. These systems are not able to measure strains due to lateral forces. However, in real operating conditions, in addition to vertical forces, lateral forces are also generated by the wheel flange pressing against the rail.

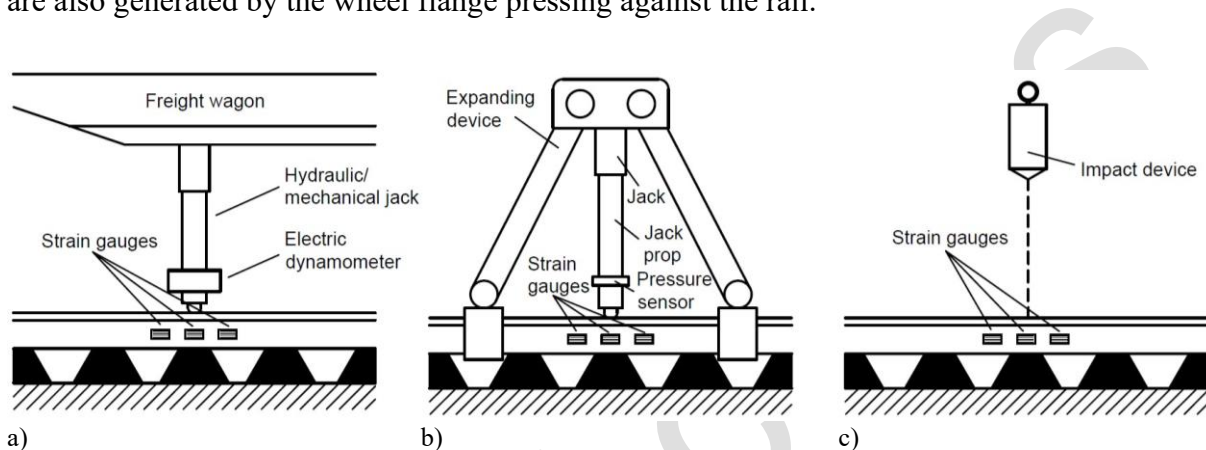

Fig. 1. Calibration systems: (a) static calibration device applied with a freight wagon, (b) static expanding calibration device, (c) dynamic impact calibration device.

There are various modifications of calibration methods based on static forces. Milkovic *et al.* [15] designed a calibration device, shown in Fig. 2a, which can independently apply vertical and lateral forces on the rail profile with hydraulic cylinders, supported by the weight of the electrical trailer unit and recording the force measurements. Bocciolini *et al.* [16] designed a system consisting of a hydraulic jack interfacing with a load cell and a device that allows the application of arbitrary forces at different predefined heights, where the vertical calibration loads are applied through a standard H-series freight wagon using an adjustable device. Kolomeets and Sych [14] designed a strain gauge calibration system, shown in Fig. 2b, that can apply static force in two different directions to the rail, with the device supported vertically by the train's front crossbeam using the weight of the electrical trailer unit, and horizontally by a hydraulic cylinder on the rail. Zhou *et al.* [17] developed the a hydraulic drive device shown in Fig. 2c, a static loading calibration device in which the hydraulic cylinder is independently supported using adjustable rods for lateral loading, while two gripper structures mounted on two crossbars are used to support the hydraulic cylinder for vertical loading. In the study conducted by Peng *et al.* [18], a special calibration device shown in Fig. 2d was designed, supported by a foundation support, jack, pull rod, jack prop, pressure sensor, pressure head, and rail clamp; additionally, the detailed structure of the rail clamp, consisting of three side clamps, includes mechanisms to facilitate the movement of the calibration device to other parts of the rail.

Strain gauge calibration systems can have various designs, as illustrated in Fig. 2. These designs must be created by following methodically determined principles that any engineer with basic engineering training can adhere to, regardless of their skills and experiences. Therefore, systematic design methods have been developed to provide a scientific process that allows for more solution options than traditional design processes and leads to the best design solution.

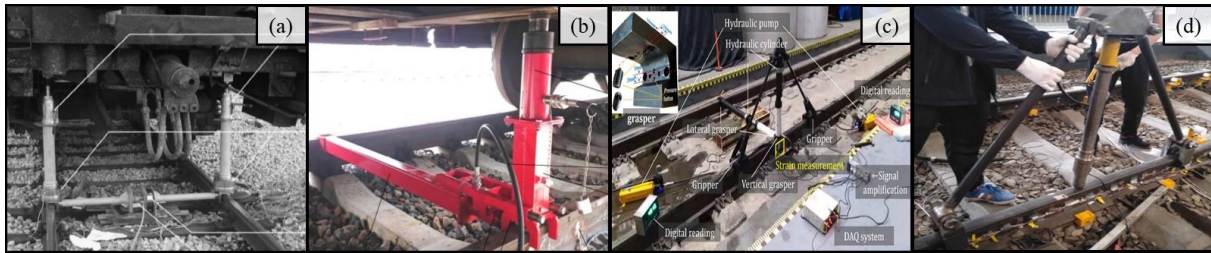

Fig. 2. Calibration devices based on static forces: (a) from Milkovic *et al.* [15], (b) from Kolomeets and Sych [14], (c) from Zhou *et al.* [17], (d) from Peng *et al.* [18].

To establish a standard in design, methodologies have been driven by the groundbreaking contributions of several key figures in the field. To begin with, French [19] concentrated on the conceptual phase of design and highlighted the importance of decision-making processes. Pahl and Beitz [20] introduced a systematic methodology for engineering design that has been widely adopted in engineering education and practice. Consequently, the *German Engineering Society* (VDI), influenced by Pahl and Beitz's ideas, introduced VDI 2221 [21], the first standard defining a systematic approach to engineering design, which formalized their methodology. In a related effort, Hubka and Eder [22] emphasized the integration of functions and technical solutions to understand technical systems. Following this, Pugh [23] focused on decision-making processes in design and introduced tools such as the decision matrix to evaluate concepts. Cross [24] combined systematic design theory with practical applications. Around this period, Suh [25] proposed the axiomatic design framework for structuring design into functional and physical domains. Lastly, Ullman [26] described the design process with decision-making methods and practical applications.

Among the design methodologies in the literature, the systematic design method developed by Pahl and Beitz and later refined by Feldhusen and Grote [27] stands out. This method enables designers to identify problems crucial to the project's continuation through creative thinking, determine solution principles by evaluating multiple criteria, and achieve the optimal design through technical and economic evaluation. In this study, a static calibration device for the calibration of strain gauges in wayside methods has been designed using the systematic design approach proposed by Pahl and Beitz and further developed by Feldhusen and Grote. The methodology used allowed the development of a modular design that can calibrate both lateral and vertical forces in the rails and is superior to existing designs.

## 2. Design of the calibration device

This study aims to design a device that can apply force to the rail and measure it to calibrate the strain gauge rosettes on the rail. This design will be implemented systematically. The systematic design process is divided into four main stages as shown in Fig. 3. In the task clarification stage, the requirements and constraints of the product are determined in detail. In the conceptual design stage, the basic solution is determined, functional structures are created and the appropriate solution principle is found by combining the operating principles. In the embodiment design stage, involves developing the design through form and material selection, calculations, and layout refinement, leading to a finalized structure with initial parts and production documentation. The final stage, detail design, includes preparing technical drawings, production and quality control documents to make the design ready for manufacturing. Additionally, prototype production may also occur between these stages. While prototype production may be necessary at any stage of the design process, it is a significant step in mass production processes, but is often economically or practically unfeasible in individual or heavy industrial production [27].

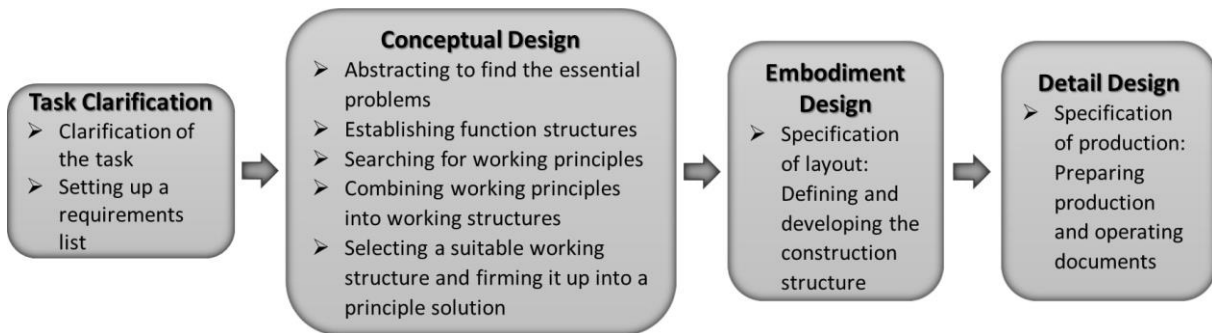

Fig. 3. Systematic design schema.

In this study, task clarification and conceptual design of a strain gauge calibration system used in wayside methods for the measurement of wheel-rail contact forces have been carried out.

### 2.1. Clarifying the Task and Setting Up the Requirements List

The design process commenced with the task clarification. During this stage, the task was determined, and its limits were defined. The task is to design a flexible, safe, user-centered, aesthetic, and innovative wayside strain gauge calibration system for wheel-rail contact force measurements. The design specification, outlining the principles to be followed throughout all design stages for the intended calibration device, is provided in Table 1. According to the systematic approach, the requirements list is a dynamic document that can be updated as needed throughout the design process. The requirements in the list are defined as *Definite Requests* (D) and *Wishes* (W).

Table 1. Requirements list

Design Specification	
Wayside Strain Gauge Calibration Device	
D, W	Requirements
D	The system must be capable of applying force to the rail and should have a structure that allows for measuring this applied force, whose level is known, with strain gauges attached to the rail.
D	It must be designed to allow measurement with static forces.
W	If possible, the system should have a design that does not require support from the wagon or rail.
D	The system must be capable of measuring both lateral and vertical forces.
W	If possible, vertical and lateral forces should be applied with a single <i>device</i> .
D	The device must be capable of applying forces in the range of 0-50 kN both horizontally and vertically on the rail.
W	Force should be manually applicable using human power.
W	Force can be transmitted through methods such as hydraulic systems, pneumatic systems, and mechanical jacks.
W	The system should be operable manually with mechanical equipment.
D	The system must have a compact structure (max 1.6 × 0.8 × 0.6 m).
D	The system must have a total weight capacity within human carry limits (max total system weight: 35 kg; max weight per piece: 10–12 kg.)
W	If possible, the system should be designed to be disassemblable and easily assembled (max assembly time: 20–25 min).
D	The device's geometry and components must have an injury-preventive and safe design.
W	The system can be used with data acquisition devices, computers, and load cells.
W	If possible, force should be readable from digital displays.
D	The system must be made of stainless, durable, and long-lasting materials.

## 2.2. Abstracting to Identify the Essential Problems

Following the examination of the requirement list, a generalization was made based on the specified requests and constraints, leading to abstraction. As a result, the essential needs were identified and simplified as follows:

- applying force to the rail and calibrating strain gauges by measuring both lateral and vertical forces;
- static force application and force application capacity up to 50 kN;
- compact and lightweight design, easy installation, safe and durable.

In conclusion, the fundamental problem to be addressed for this design is defined as "Accurate and precise calibration of strain gauges attached to the rail with a safe, simple, compact and easy-to-use device capable of applying vertical and lateral force"

## 2.3. Establishing Function Structures

Function structures specify the functions of the technical system in terms of their input-output relationships. Based on the general problem definition obtained through abstraction, the fundamental principle of the designed wayside measurement system has been established. According to the established fundamental principle, the main function structure (black box) has been formed by aligning input-output quantities with the flow of Material (M-M'), Signal (S-S'), and Energy (E-E'), as depicted in Fig. 4.

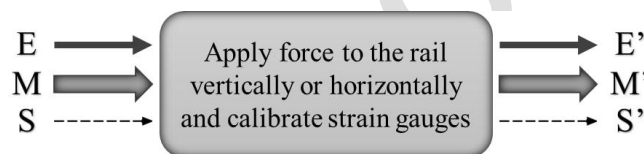

Fig. 4. Black box diagram of the calibration device.

The detailed function structure of the system is shown in Figure 5. The overall function structure has been detailed in this diagram, and the operational principles of the system have been schematically outlined. Strain gauges, the calibration device, and the data acquisition system are depicted as three separate input components. Processes such as the attachment of strain gauges to the rails, the stabilization and assembly of the system, and the application of force are carried out using mechanical energy. In contrast, the data acquisition system and the computer operate with electrical energy. The transfer, reading, and processing of data to achieve calibration are illustrated within the signal flow.

A chain of functions containing key sub-functions for the design can be created to facilitate subsequent solution searches [28]. A chain of functions, shown in Table 2, has been created by selecting important sub-functions for the design of the strain gauge calibration system, as depicted in the function structure in Fig. 5. The attaching strain gauge and its configuration are not included in the function chain as they are independent of the calibration device design.

## 2.4. Searching for and Combining Working Principles

Appropriate solutions are sought for each important sub-function identified in the function chain shown in Table 2. Solution alternatives can be investigated using traditional, heuristic or non-heuristic methods. In this study, traditional methods such as literature review and analysis of existing systems are used to identify solution alternatives. In addition, brainstorming technique, which is among the heuristic methods, was also utilised. As a result, the solution

alternatives determined for the sub-functions are presented in Table 3. The design variants created with appropriate combinations of the sub-solutions in Table 3 are presented in Table 4.

Table 2. Requirements list

Functions		Definition of Function
<b>Overall function</b>	<b>Primary function</b>	Applying force to the rail both vertically and horizontally and calibrating the strain gauges
<b>Sub-functions</b>	<b>Second-order functions</b>	1. Fixing the system to the rail
		2. To carry out the assembly, installation, and connection of the system.
		3. Applying force to the rail
		4. Measuring the applied force to the rail
	<b>Third-order functions</b>	1.1. Securing the system in the vertical direction
		1.2. Securing the system in the horizontal direction
		1.3. Balancing the system
		1.4. Supporting the system
		3.1. Applying force vertically up to 50 kN
		3.2. Applying force horizontally up to 50 kN
		3.3. Generating force
		3.4. Transmitting the force to the rail
4.1. Reading the force applied to the rail		

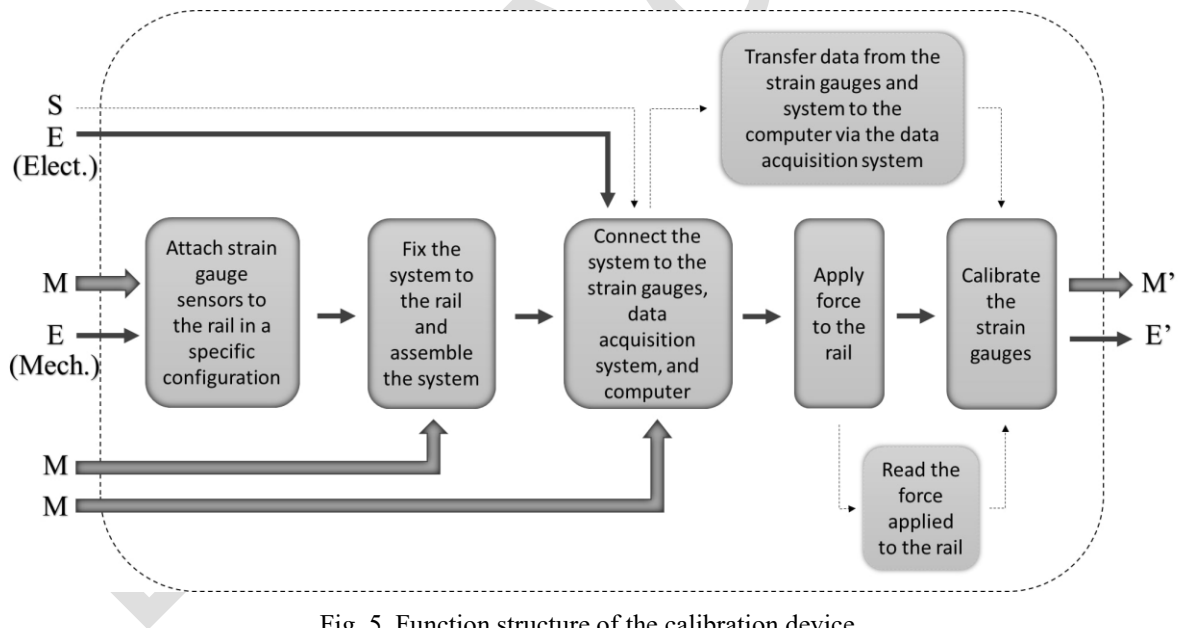

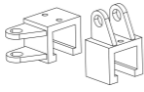



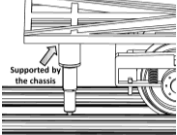
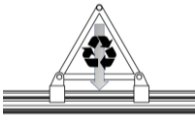
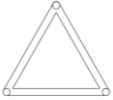

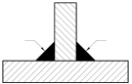
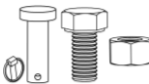
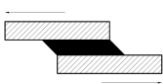
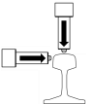

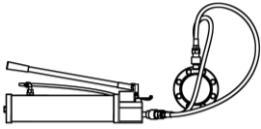

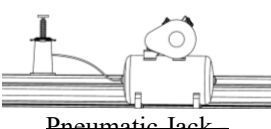

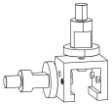
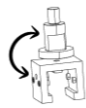





Fig. 5. Function structure of the calibration device.

### 2.5. Selecting Suitable Combinations

The sub-functions listed in the function chain in Table 2 were transferred to the morphological chart in Table 3, where solutions were then explored for each sub-function. These sub-functions include: securing the system, balancing the system, supporting the system, assembling the system, making connections of the system, applying force vertically and horizontally, generating force, transmitting force, and reading the force applied to the rail. Solutions were developed for these sub-functions based on the required functionality, and the resulting alternatives are presented in Table 3.

Table 3. Prioritized design solutions identified in the classification scheme

	Solution Option	Solution Option	Solution Option
Sub-functions	S1	S2	S3
Securing the system (F1)	 Without grippers	 Vert. & Horiz. gripper	 Multi-axis gripper
Balancing the system (F2)	 Spirit level	 Digital level	 Laser level
Supporting the system (F3)	 Supported by the vehicle	 Self-supported	-
Assembling the system (F4)	 Monolithic structure	 Portable modular structure	-
Making connections of the system (F5)	 Welded joints	 Pins, bolts and nuts	 Adhesive Bonds
Applying force vertically and horizontally (F6)	 2 separate system, vert. & horiz. force	 Single system, vert. & horiz. force	-
Generating force (F7)	 Hydraulic Jack - Hand Pump	 Mechanical Jack - Manual Lifting System	 Pneumatic Jack - Compressor
Transmitting Force (F8)	 Force transfer apparatus - without a pressure head	 2 force transfer apps. - multi-axis pressure head	 Force transfer apparatus - multi-axis pressure head
Reading the force applied to the rail (F9)	 Analog Gauge	 Digital Display	 Analog Gauge, Dig. Display & Computer Integrated

Analysis of the results presented in Table 3 reveals that initially up to 5832 concept variants were accessible. However, some solutions that did not meet the requirements listed in the table, or those involving implementation difficulties, insufficient production or application experience, or high costs, were excluded during the pre-evaluation stage. Additionally, the sub-functions F1S1-F3S2, F1S3-F3S1, F6S1-F8S3, F6S2-F8S2, F3S1, and F6S2 were identified as incompatible combinations, and therefore, the variants containing these combinations were eliminated. Consequently, after reducing the solution options, three distinct variants remain for system design. These variants are presented in Table 4.

Table 4. The design alternatives derived from the effective integration of the sub-solutions

<b>Variant 1</b>	F1S1 - F2S1 - F3S1 - F4S2 - F5S2 - F6S1 - F7S1 - F8S2 - F9S3
<b>Variant 2</b>	F1S3 - F2S1 - F3S2 - F4S2 - F5S2 - F6S1 - F7S1 - F8S2 - F9S3
<b>Variant 3</b>	F1S3 - F2S1 - F3S2 - F4S2 - F5S2 - F6S2 - F7S1 - F8S3 - F9S3

## 2.6. Firming Up into Principle Solution Variants

To make a decision on the most suitable principle solution (concept) variant, the selected solution options must be improved to enable evaluation [27]. This necessitates the creation of appropriate design concepts, such as those presented in Figs 6, 7, 8.

The conceptual design of Variant 1 is illustrated in Fig. 6. In the designed system, a gripper is not used; instead, the system is supported vertically by a height-adjustable jack-like mechanism (7, 8) with the wagon beam and horizontally with the rails. The system's balance is controlled by spirit levels (6) positioned on the hydraulic cylinders (5). The system consists of a portable modular structure connected with pins, bolts, and nuts, allowing force application in both horizontal and vertical directions. Using two manual hydraulic pumps (10), force is transmitted to the multi-axis pressure heads (2) via force transmission apparatuses (3). The multi-axis pressure heads (2) then transfer the force to the rail through the tips inside them. The force applied to the rail can be tracked by the dial on the hydraulic hand pump (14), the digital display (15) on the load cell transmitter (11), and the computer (13). The computer (13) records and analyses the data transmitted from the strain gauges (1) and loadcell (4) to the *DAQ* (12). As a result, the strain gauge set is calibrated to function as a traceable reference that can measure loads with the same accuracy as the load cell (4) by using the load cell ( $mV/V \rightarrow N$ ) calibration procedure and the linear correlation created by simultaneous measurements ( $F = k \cdot \epsilon$ ).

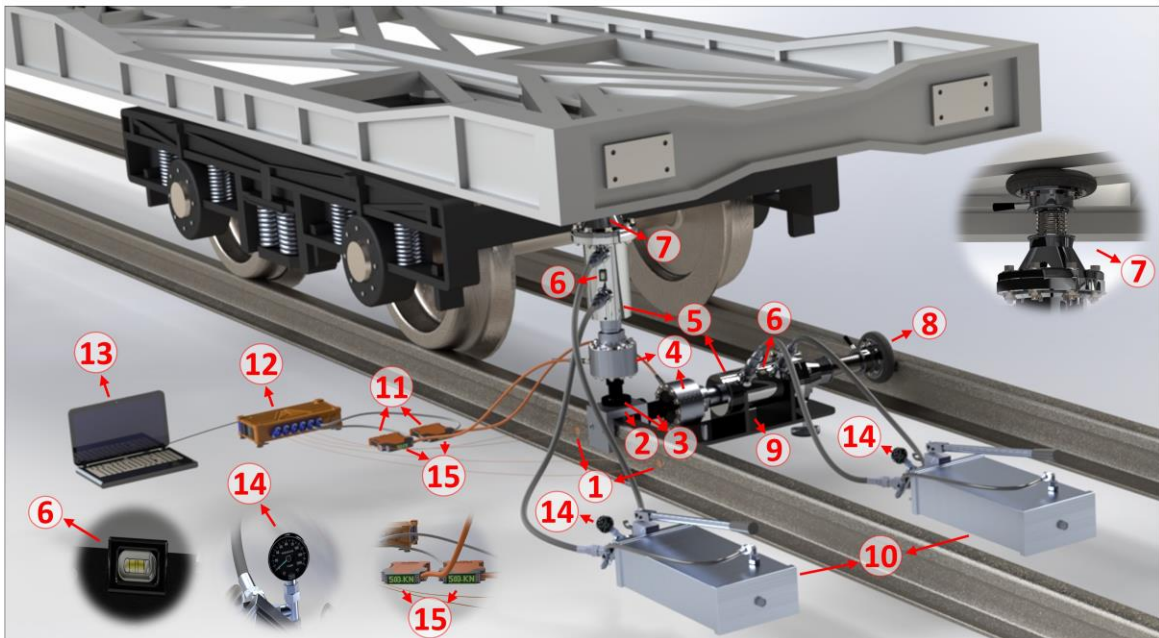

Fig. 6. Variant 1: 1 - strain gauges, 2 - pressure head, 3 - force apparatus, 4 - load cell, 5 - hydraulic cylinder, 6 - spirit level, 7 - vertical support adjustment, 8 - horizontal support adjustment, 9 - horizontal support platform, 10 - hand pump, 11 - load cell transmitter, 12 - DAQ, 13 - laptop, 14 - analog gauge, 15 - digital display.

The design concept of Variant 2 is displayed in Figure 7. The designed self-supported system consists of 2 devices, vertical and horizontal. The vertical calibration device is fixed to the rail using grippers (2), while the horizontal calibration device is secured to both the rail and the horizontal support platform (8) using grippers (2). System equilibrium in both horizontal and vertical devices is maintained by a spirit level (7) on the top plate. Force is delivered to the multi-axis pressure heads (3) through force transmission apparatuses (4) by means of two manual hydraulic pumps (9). The dial on the hydraulic hand pump (13), the digital display (14) on the load cell transmitter (10), and the computer (12) allow monitoring of the force applied to the rail. Data from the strain gauges (1) and load cell (5) is transmitted to the *DAQ* (11), where it is recorded and analyzed by the computer (12). The calibration process of the load cell (5) provides a directly traceable reference for the strain gauge set. Simultaneous measurements enable the calibration of the strain gauge set, ensuring its accuracy matches that of the load cell.

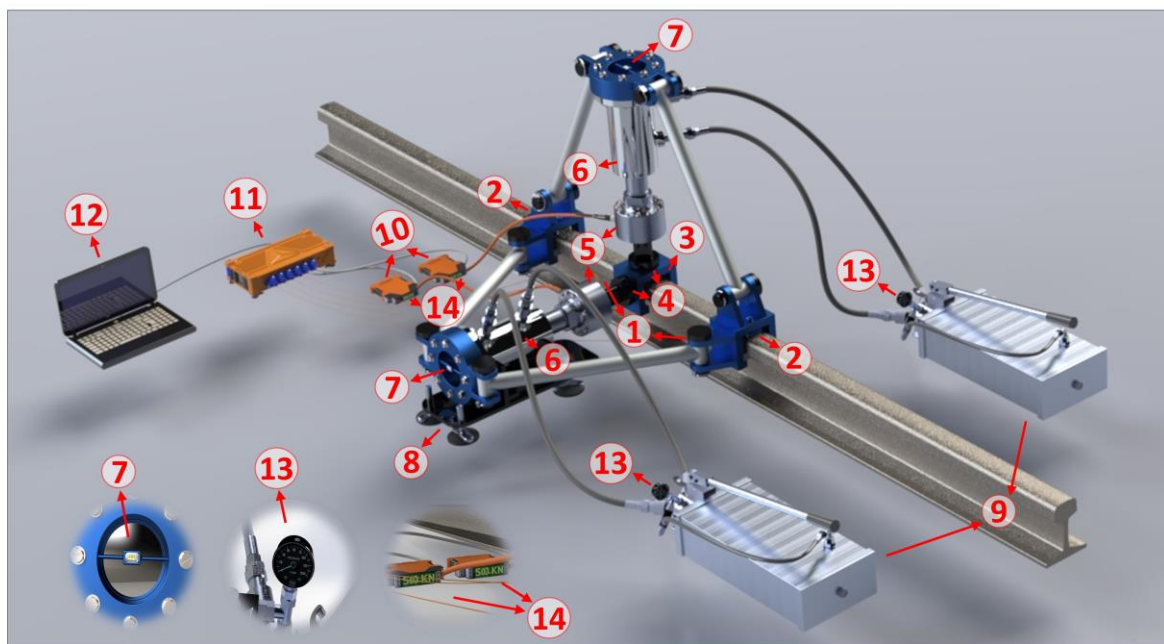

Figure 7. Variant 2: 1 - strain gauges, 2 - grippers, 3 - pressure head, 4 - force apparatus, 5 - load cell, 6 - hydraulic cylinder, 7 - spirit level, 8 - horizontal support platform, 9 - hand pump, 10 - load cell transmitter, 11 - DAQ, 12 - laptop, 13 - analog gauge, 14 - digital display.

The schematic representation of Variant 3 is shown in Figure 8. The designed self-supported calibration device can measure both horizontal and vertical loads with a single system. The calibration device is fixed vertically on the rail using grippers (2) and horizontally with a special horizontal support platform (8) and grippers (2) on the rail. System stability is ensured in both horizontal and vertical configurations through a spirit level (7) positioned on the top plate to apply force precisely. To generate pressure in the hydraulic cylinders (6), an independent manual hydraulic pump (9) connected to the hydraulic cylinders (6) via high-pressure hoses is used. The pressure in the hydraulic cylinder (6) is transferred to the rail through a force transfer apparatus (4) and a multi-axis pressure head (3), which includes a tip inside the pressure head.

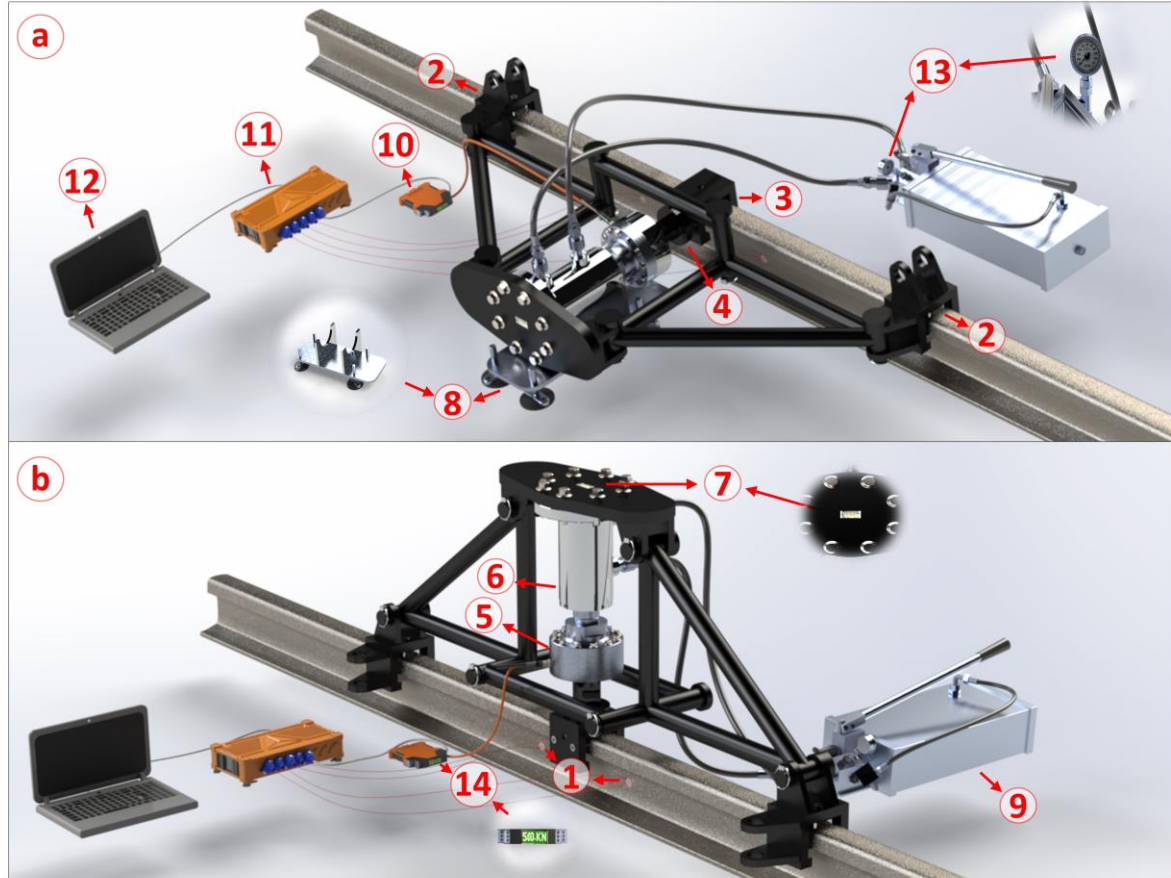

Fig. 8. Horizontal (a) and vertical (b) usage of Variant 3: 1 - strain gauges, 2 - grippers, 3 - pressure head, 4 - force apparatus, 5 - load cell, 6 - hydraulic cylinder, 7 - spirit level, 8 - horizontal support platform, 9 - hand pump, 10 - load cell transmitter, 11 - DAQ, 12 - laptop, 13 - analog gauge, 14 - digital display.

The force transmitted to the rail can be monitored in real-time via the dial on the hydraulic hand pump (13), the digital display (14) on the load cell transmitter (10), and the computer (12). While the manual hydraulic pump (9) supplies pressure to the hydraulic cylinder (6), a data acquisition system (11) transmits data from the strain gauge (1) and load cell (5) to the computer (12). The computer (12) records and analyzes this data to ensure the accuracy of the calibration process. Through the linear correlation ( $F = k \cdot \varepsilon$ ) established by simultaneous measurements during the load cell (5) calibration process ( $\text{mV/V} \rightarrow \text{N}$ ), the strain gauge set can be calibrated and thus made as accurate as the load cell itself.

## 2.7. Evaluating Principle Solution Variants

In the Selecting Suitable Combinations section, 3 different design variants were created as shown in Table 4 and schematised in the Firming Up into Principle Solution Variants section. However, the number of designs should be reduced to one by selecting the optimum design among these variants. For this purpose, additional selection procedures such as the objectives tree (design/implementation of the criteria and importance of the design), the value profile diagram (balanced distribution of the criteria), *etc.* can be used [29]. The objectives tree is created to achieve a hierarchical arrangement, with each technical and economic goal weighted according to its significance. Figure 9 illustrates the weighted objectives tree related to the problem. In the figure, "G" stands for goal, " $G_i$ " represents goals at level  $i$ , and " $G_{ij}$ " denotes sub-goals at level  $ij$ .

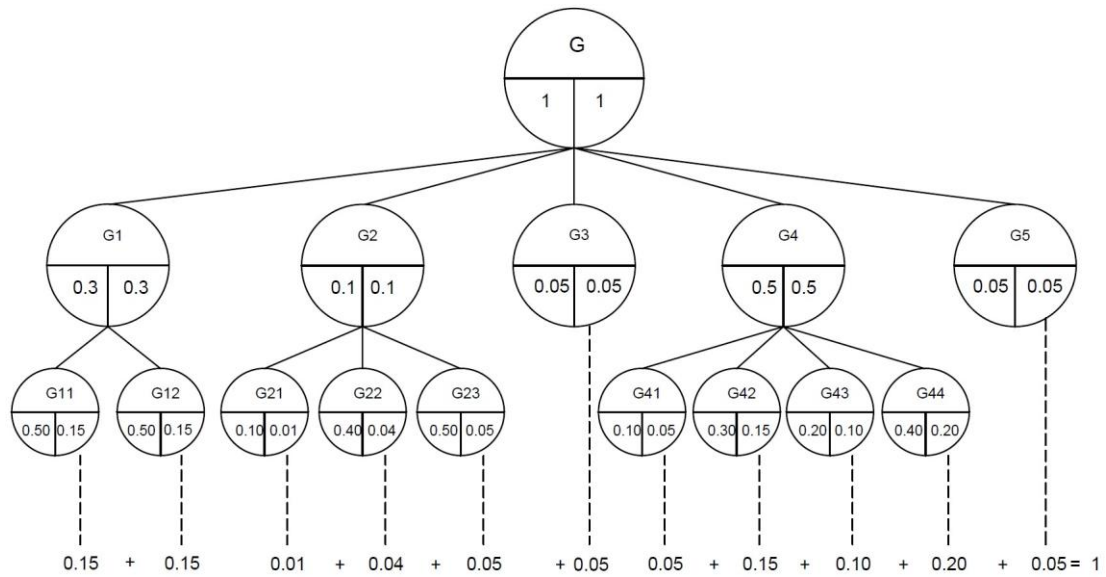

Figure 9. Weighted objectives tree.

The objectives are defined as follows:

*G*: Optimum calibration device;

*G1*: Ease of Use, *G11*: Compactness, *G12*: Ergonomic;

*G2*: Simplicity, *G21*: Ease of Production, *G22*: Ease of Maintenance, *G23*: Ease of Installation;

*G3*: Cost (Cheapness);

*G4*: High Mechanical Properties, *G41*: Low Noise, *G42*: Long Life, *G43*: Safety, *G44*: Lightness;

*G5*: Aesthetics.

The next step is the evaluation of the defined weighted objectives, which constitutes the main assessment process. These values inherently possess a certain degree of subjectivity, as they are derived from the consideration of the relative scales of the previously determined parameters. For this evaluation, either Use–Value Analysis, which employs a range from 0 to 10, or Guideline VDI 2225, which uses a range from 0 to 4, can be applied [27]. In this study, Use–Value Analysis was preferred, as it provides a wider range through a decimal system, thereby facilitating the evaluation process. The evaluation scale used in this study is presented in Table 5.

Table 5. Value scale.

Use-value analysis											
Meaning	Absolutely useless solution	Very inadequate solution	Weak solution	Tolerable solution	Adequate solution	Satisfactory solution	Good solution with few drawbacks	Good solution	Very good solution	Solution exceeding the requirement	Ideal solution
Points	0	1	2	3	4	5	6	7	8	9	10

For each variant, the evaluation of the weighted objectives was conducted by experts in the field, who assigned scores within the 0–10 range. Subsequently, the weighted score for each concept was calculated by multiplying the score of each variant by the determined weight factor (e.g.,  $V1 = 6 \times 0.15 + 4 \times 0.15 + \dots = 6.42$ ). The results of the technical and economic evaluations are presented in Table 6.

Table 6. Evaluation chart

	Compactness	Ergonomic	Ease of Production	Ease of Maintenance	Ease of Installation	Cost (Cheapness)	Low Noise	Long Life	Safety	Lightness	Aesthetics	Weighted score
	G11	G12	G21	G22	G23	G3	G41	G42	G43	G44	G5	
	0.15	0.15	0.01	0.04	0.05	0.05	0.05	0.15	0.10	0.20	0.05	
V1	6x	4x	8x	6x	8x	4x	10x	8x	8x	6x	6x	6.42
V2	4x	6x	6x	6x	8x	2x	10x	8x	10x	6x	6x	6.50
V3	8x	8x	8x	6x	10x	8x	10x	8x	10x	8x	8x	8.32

Based on the evaluation of technical and economic criteria, the analysis of the results presented in Table 6 clearly indicates that Variant 3 is the most suitable solution. Variant3, identified as the optimal solution, stands out compared to other solutions in terms of compactness, ergonomics, ease of production, ease of installation, cost, safety, lightness, and aesthetics. Additionally, it distinguishes itself by being able to apply both vertical and horizontal forces with a single system and not requiring a vehicle or other rail support during measurement. For example, since Variant1 is mounted under the vehicle for use, the vehicle's wheel loads will also affect the measurement point. Therefore, for the force applied by the device to be used directly for calibration purposes, the wheel loads must be known and their effects on the measurement point must be calculated. In contrast, Variant 3 is highly advantageous because it was designed so that the grippers holding the rail are positioned close to the sleeper support points, preventing both additional stresses at the measurement location and any loads transmitted from the vehicle. Consequently, the design process can proceed with Variant 3 into the embodiment and detailed design phases, allowing for the further development and finalization of the selected concept.

## 2.8. Subsequent Design Phases: Embodiment Design, Prototyping, and Detail Design

In this section, the design process following the conceptual phase, which concluded with the derivation of Variant 3, is briefly summarized, including the subsequent embodiment design phase, the prototype production and testing, and finally the detail design phase.

Embodiment design aims to transform the most suitable variant (Variant 3) determined in the conceptual design phase into a technical layout. At this stage, a preliminary layout is created by elaborating the sub-functions in the selected design by determining the basic parameters such as the general structure of the design, material selection, dimensioning. Then, the definitive layout is obtained by eliminating the weak points on this preliminary layout, improving the structural strength, manufacturability and cost-effectiveness. This definitive layout represents the final solution that meets the technical requirements of the design, verified by detailed technical analyses.

In the preliminary layout phase of the embodiment design, the integration of the sub-functions of Variant 3 has been carried out. Firstly, the sub-functions of Variant 3 have been detailed to ensure that the design meets technical and operational requirements. All sub-functions were analyzed in accordance with the overall structure of the system based on criteria such as functionality, reliability, and modularity, and embodiment design decisions were made for each sub-function.

In the main frame design, AISI 4140 steel with a hardness of 45-50 HRC and a hardness depth of 0.8 mm was selected for critical areas such as the chassis top plate and clamps due to its high strength and deformation resistance. AISI 1040 steel was chosen for secondary

structures to ensure cost efficiency. The designed system will apply forces in the range of 0-50 kN to the rail. Due to the high applied force, static analyses of the chassis were performed to verify the suitability of the design parameters and to evaluate the mechanical performance, reliability, and safety of the system under working loads. The finite element model of the test device was created using Altair/Hypermesh 2019 software, and finite element analyses were performed using Ansys 2023 R2 software. Structural analyses of the calibration device were performed using the finite element method for both vertical and horizontal conditions, and the stress and deformation results are shown in Figure 10.

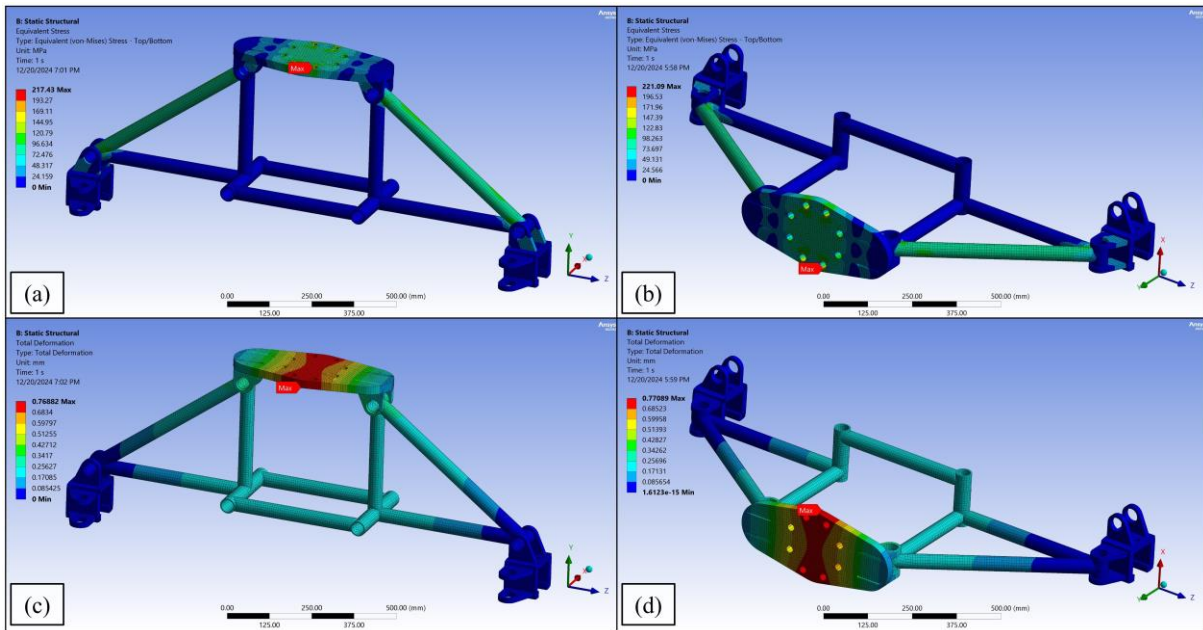

Fig. 10. Stress (a), (b) and deformation (c), (d) results for the vertical and horizontal cases.

According to the structural analysis results, the maximum Von Mises stress in the system was calculated as 217.43 MPa in the vertical configuration and 221.09 MPa in the horizontal configuration. In both configurations, the stress is concentrated on the upper plate and is well below the material's yield strength of 415 MPa. The damage factor ( $U$ ) was calculated as 0.52 for the vertical configuration and 0.53 for the horizontal configuration, indicating that 52% and 53% of the material's load-bearing capacity is utilized, respectively. This demonstrates that the safety factor is adequate and the material can operate under load without deformation. The maximum deformation observed in the system is 0.76882 mm in the vertical direction and 0.77089 mm in the horizontal direction, which is at a level that will not adversely affect the functionality of the system. These findings confirm that the material selection and structural design effectively ensure safe and reliable performance under vertical and horizontal loading conditions. Since no structural adjustments were required based on the analysis, this design was advanced to the definitive layout phase.

In the definitive layout phase, the design obtained in the preliminary layout stage was evaluated in terms of modularity, assembly and manufacturability, ergonomics, and safety. The system was designed with a modular structure to allow for the independent manufacturing and assembly of each module. Compatibility was ensured by selecting components such as standard bolts and pins, simplifying the assembly processes.

The exploded assembly view of the calibration device chassis for the vertical configuration, as shown in Fig. 11a., consists of one upper connection plate (1), two components numbered (7), two components numbered (12), four bushing components (14), a spirit level (11), a

hydraulic cylinder (2), a load cell (3), a force apparatus (4), a pressure head (5) with pressure tip (6), four components numbered (13), left and right grips (14, 15), laminations (16), and wedges (17). In vertical operation, the device is securely fixed to the rail using grippers (15, 16) consisting of laminations (17) and wedges (18) and assembled with four short pins (9), two long pins (8), and six clamp pins (10).

When the system is configured for horizontal operation, as shown in Figure 11.b, the device is fixed to the ground using a special horizontal support platform (19, 20) and to the rail using the same grippers (15, 16, 17, 18). In this configuration, the long pins (8) are replaced with medium-length pins (13), and one component (12) and two bushing components (14) are removed from the chassis. To ensure secure assembly in the horizontal configuration, six clamp pins (10) are used to fasten the hinges into their slots. The same type of connection is used for all six hinges, ensuring stability and durability in both configurations.

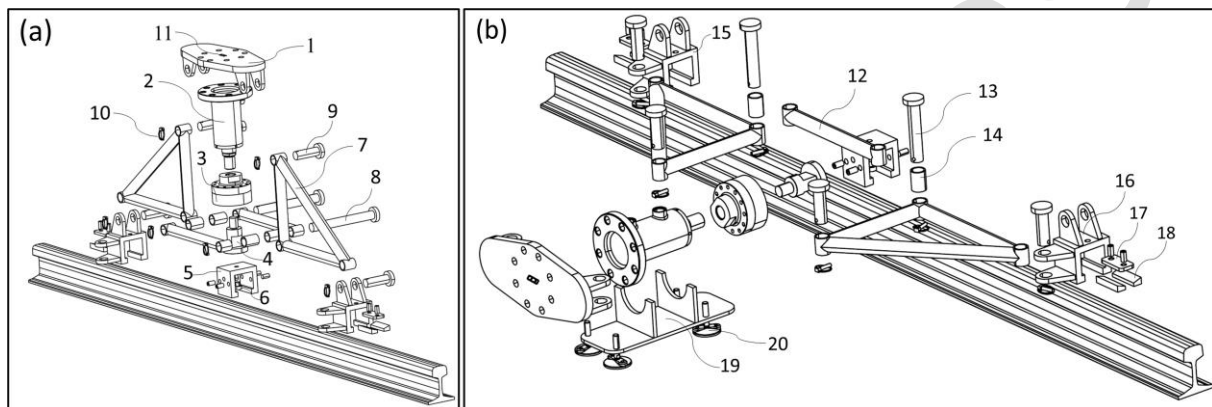

Fig. 11. Exploded view of the calibration device: (a) vertical usage, (b) horizontal usage.

The embodiment design process elaborated on the most suitable variant identified in the conceptual design phase and resulted in the final design. During this process, structural analyses were carried out to verify that the design could operate safely under operational loads. The modular design approach increased operational efficiency and flexibility in terms of assembly, maintenance and portability, while the standardized components used were intended to facilitate production processes. This final design, in which the sub-functions are integrated harmoniously with each other, is ready for the detail design.

Prototype production and testing are highly significant in providing insights and supporting innovative solutions throughout all stages of the design process. The iterative and integrated use of prototypes ensures the optimization of the design from its inception to production [30]. Prototyping is a critical tool for evaluating functionality and assessing user needs. The development of prototypes aims to meet technical requirements and enhance user experiences [31].

The design stages shown in Figure 3 do not specifically include model and prototype production, as the information provided by these tools may be required at every design process point. Thus, model or prototype production cannot be placed as a distinct design step. In many cases, even during the conceptual design phase, creating models and prototypes may be necessary [27]. During the Embodiment Design phase, prototypes are produced to test the accuracy of the design concept and its technical suitability, while more advanced prototypes can also be created during the Detailed Design phase.

In this study, a prototype was created during the Embodiment Design phase, specifically at the definitive layout stage, to evaluate elements such as structural durability under real-world conditions. This prototype enabled the testing of the design's ability to meet technical requirements, the compatibility of components, and overall performance. Based on the

feedback obtained from these tests, the calibration device achieved highly successful results. Thus, before the Detailed Design phase, where dimensions, tolerances, and material properties would be finalized, the product's success was ensured. The application of the prototype in vertical and lateral cases is shown in Fig. 12.

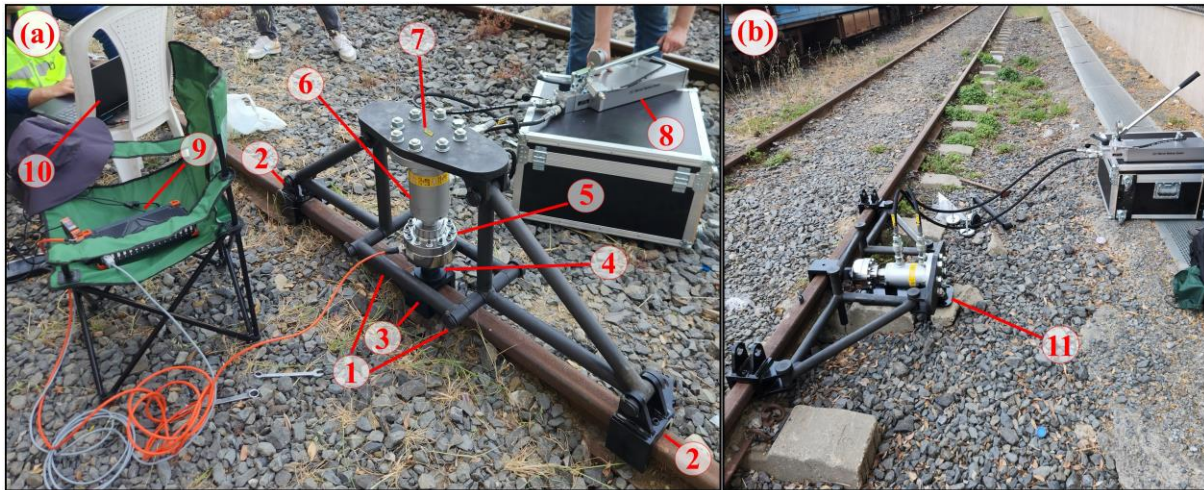

Fig. 12. Vertical (a) and horizontal (b) application of the calibration system: 1 - strain gauges, 2 - grippers, 3 - pressure head, 4 - force apparatus, 5 - load cell, 6 - hydraulic cylinder, 7 - spirit level, 8 - hand pump, 9 - DAQ, 10 - laptop, 11 - horizontal support platform.

In this design process, following the conceptual design and prototype production, the detailed design phase is initiated. In this phase, the layout, shapes, dimensions, and other characteristics of all components are finalized. Cost estimates are made, and all necessary production documents, including detailed drawings and assembly instructions, are prepared. As a result, the detailed design phase ensures that the design is converted into accurate production information, making the design ready for production.

### 3. Conclusions

In this study, a device for calibrating strain gauges used to measure wheel-rail contact forces in wayside methods is designed. In the design process, firstly, the task is clarified and the requirements list is created. In the conceptual design phase, the fundamental problem was identified by abstraction, functional structures were created, working principles were investigated and combined. Afterwards, suitable combinations were selected, and steps such as identifying principle solution variants and evaluating these variants were carried out, transitioning the design to the embodiment design phase. During the embodiment design phase, the sub-functions were elaborated in detail, and subsequently, a prototype was produced. The ability of the prototype to meet the technical requirements of the design was then tested, ensuring its performance and reliability. As a result, the developed final design is considered to make a significant contribution to the literature as a device that can apply both vertical and horizontal forces with a single system, ensuring accurate and precise calibration of strain gauges on rails in wayside applications, while being safe, simple, compact, and easy to use. In addition, the developed design does not require vehicle or other rail support during measurement, which is an advantage over other existing designs in the literature.

## Acknowledgements

The financial support of the Program for Scientific and Technological Research Projects (1001) by the Scientific and Technical Research Council of Turkey (TUBITAK) (Project No: 222M001) is gratefully acknowledged.

## References

- [1] Wu, P., Zhang, F., Wang, J., Wei, L., & Huo, W. (2023). Review of wheel-rail forces measuring technology for railway vehicles. *Advances in Mechanical Engineering*, 15(3). <https://doi.org/10.1177/16878132231158991>
- [2] Matsumoto, A., Sato, Y., Ohno, H., Tomeoka, M., Matsumoto, K., Kurihara, J., Ogino, T., Tanimoto, M., Kishimoto, Y., Sato, Y., & Nakai, T. (2008). A new measuring method of wheel–rail contact forces and related considerations. *Wear*, 265(9–10), 1518–1525. <https://doi.org/10.1016/j.wear.2008.02.031>
- [3] Matsumoto, A., Sato, Y., Ohno, H., Shimizu, M., Kurihara, J., Tomeoka, M., Saitou, T., Michitsuji, Y., Tanimoto, M., Sato, Y., & Mizuno, M. (2012). Continuous observation of wheel/rail contact forces in curved track and theoretical considerations. *Vehicle System Dynamics*, 50(sup1), 349–364. <https://doi.org/10.1080/00423114.2012.669130>
- [4] Bracciali, A., Cavaliere, F., & Macherelli, M. (2014). Review of Instrumented Wheelset Technology and Applications. *Civil-comp Proceedings*. <https://doi.org/10.4203/ccp.104.167>
- [5] Bižić, M., & Petrović, D. (2023). Design of instrumented wheelset for measuring wheel-rail interaction forces. *Metrology and Measurement Systems*, 563–579. <https://doi.org/10.24425/mms.2023.146424>
- [6] Bellacci, G., Entezami, M., Weston, P. F., & Pugi, L. (2025). Estimation of railway track vertical alignment using instrumented wheelsets and contact force recordings. *Machines*, 13(10), 963. <https://doi.org/10.3390/machines13100963>
- [7] Delprete, C., & Rosso, C. (2008). An easy instrument and a methodology for the monitoring and the diagnosis of a rail. *Mechanical Systems and Signal Processing*, 23(3), 940–956. <https://doi.org/10.1016/j.ymsp.2008.06.004>
- [8] Molatefi, H., & Mozafari, H. (2013). Analysis of new method for vertical load measurement in the barycenter of the rail web by using FEM. *Measurement*, 46(8), 2313–2323. <https://doi.org/10.1016/j.measurement.2013.04.008>
- [9] Askarnejad, H., Dhanasekar, M., Boyd, P., & Taylor, R. (2012). Field measurement of Wheel-Rail impact force at insulated Rail Joint. *Experimental Techniques*, 39(5), 61–69. <https://doi.org/10.1111/j.1747-1567.2012.00867.x>
- [10] Cortis, D., Bruner, M., Malavasi, G., Rossi, S., Catena, M., & Testa, M. (2016). Estimation of the wheel-rail lateral contact force through the analysis of the rail web bending strains. *Measurement*, 99, 23–35. <https://doi.org/10.1016/j.measurement.2016.12.015>
- [11] Cortis, D., Bruner, M., & Malavasi, G. (2020). Development of a wayside measurement system for the evaluation of wheel-rail lateral contact force. *Measurement*, 159, 107786. <https://doi.org/10.1016/j.measurement.2020.107786>
- [12] CEN. (2022). Railway applications – Testing for the acceptance of running characteristics of railway vehicles – Testing of running behaviour and stationary tests (BS EN 14363:2016+A2:2022). European Committee for Standardization. <https://standards.cencenelec.eu>
- [13] Lu, P., Li, X., Cui, D., An, B., & Jiang, W. (2025). Identification method of wheel-rail two-point contact state in switch area. *Scientific Reports*, 15(1), 3657. <https://doi.org/10.1038/s41598-025-85687-8>
- [14] Kolomeets, A., & Sych, T. (2018). Calibration method for a strain-gauge measurement system based on bidirectional rail loading. *MATEC Web of Conferences*, 216, 03005. <https://doi.org/10.1051/mateconf/201821603005>
- [15] Milković, D., Simić, G., Jakovljević, Ž., Tanasković, J., & Lučanin, V. (2013). Wayside system for wheel–rail contact forces measurements. *Measurement*, 46(9), 3308–3318. <https://doi.org/10.1016/j.measurement.2013.06.017>

- [16] Bocciolini, L., Bracciali, A., Di Benedetto, L., Mastandrea, R. Piccioli, F. (2014). Wayside Measurement of Lateral and Vertical Wheel/Rail Forces for Rolling Stock Homologation. *Civil-Comp Press, Proceedings of the Second International Conference on Railway Technology: Research, Development and Maintenance* Civil-Comp Press, Stirlingshire, Scotland, 171. <https://doi.org/10.4203/ccp.104.171>
- [17] Zhou, W., Abdulhakeem, S., Fang, C., Han, T., Li, G., Wu, Y., & Faisal, Y. (2020). A new wayside method for measuring and evaluating wheel-rail contact forces and positions. *Measurement*, 166, 108244. <https://doi.org/10.1016/j.measurement.2020.108244>
- [18] Peng, X., Zeng, J., Wang, J., Wang, Q., Li, D., & Liang, S. (2022). Wayside wheel-rail vertical contact force continuous detecting method and its application. *Measurement*, 193, 110975. <https://doi.org/10.1016/j.measurement.2022.110975>
- [19] French, M. (1985). *Conceptual Design for Engineers*, 2nd edition. Berlin Heidelberg, Springer-Verlag. <https://doi.org/10.1007/978-3-662-11364-6>
- [20] Pahl, G., & Beitz, W. (1996). *Engineering design - a systematic approach*. London, Springer-Verlag <https://doi.org/10.1007/978-1-4471-3581-4>
- [21] VDI Society for Product Development. (1987). Design and Marketing, *Systematic Approach to the Design of Technical Systems and Products*, Verein Deutscher Ingenieure, Berlin, Germany.
- [22] Hubka, V., & Eder, W. E. (1988). *Theory of technical systems*. Berlin Heidelberg, Springer-Verlag <https://doi.org/10.1007/978-3-642-52121-8>
- [23] Pugh, S. (1990). *Total Design: integrated methods for successful product engineering*, Wokingham, Addison-Wesley.
- [24] Cross, N. (2000). *Engineering Design Methods: strategies for product design*, 3rd edition, Chichester, John Wiley & Sons.
- [25] Suh, N. P. (2001). *Axiomatic Design: Advances and Applications*, New York, NY, USA: Oxford University Press.
- [26] Ullman, D.G. (2010). *The Mechanical Design Process*, 4th edition, London, McGraw Hill.
- [27] Pahl, G., Beitz, W., Feldhusen, J., & Grote, K. (2007). *Engineering design*. <https://doi.org/10.1007/978-1-84628-319-2>
- [28] Çelik, A., & Azeloğlu, C. O. (2022). Sistematik yaklaşımla bir konsept tasarım uygulaması: engelli dostu spor aleti. *Gazi Üniversitesi Fen Bilimleri Dergisi Part C Tasarım Ve Teknoloji*, 10(4), 792–804. <https://doi.org/10.29109/gujsc.1110717>
- [29] Börklü, H. R., Yüksel, N., Çavdar, K., & Sezer, H. K. (2018). A practical application for machine design education. *Journal of Advanced Mechanical Design Systems and Manufacturing*, 12(2), JAMDSM0036. <https://doi.org/10.1299/jamdsm.2018jamdsm0036>
- [30] Hansen, C. A., & Özkil, A. G. (2019). From Idea to Production: A retrospective and longitudinal case study of prototypes and prototyping strategies. *Journal of Mechanical Design*, 142(3). <https://doi.org/10.1115/1.4045385>
- [31] Shehata, M. (2024). Designing smart products in the light of design thinking and the systematic design approach. *Journal of Design Sciences and Applied Arts/Journal of Design Sciences and Applied Arts*, 5(1), 310–320. <https://doi.org/10.21608/jdsaa.2023.221509.1312>



and control.

**Muzaffer Metin** received his B.Sc., M.Sc., and Ph.D. degrees in mechanical engineering from Yildiz Technical University, Istanbul, Türkiye. In 2018, he joined Yildiz Technical University as an Assistant Professor, and since 2020, he has been serving as an Associate Professor in the same department. His research interests include railway engineering, mechanical vibrations, vehicle dynamics, and system dynamics



methodology, mechanical vibrations, and railway systems.

**Abdullah Çelik** received his B.Sc. and M.Sc. degrees in mechanical engineering from Yildiz Technical University, where he is currently pursuing his Ph.D. at the Department of Mechanical Engineering. He worked as a Research Assistant at Zonguldak Bülent Ecevit University between 2020 and 2022 and has been with Yildiz Technical University since 2022. His research interests include design