

## ALTERNATIVE TO LASER VIBROMETERS: A NON-CONTACT VIBRATION MEASUREMENT BASED ON ENHANCED LASER SPECKLE PATTERN AND STROBOSCOPIC SAMPLING

Ibrahim Yildiz

Necmettin Erbakan University, Mechatronics Engineering Department, Koycegiz, Meram, Turkey (✉ [iyildiz@erbakan.edu.tr](mailto:iyildiz@erbakan.edu.tr))

### Abstract

This research introduces a novel technique for non-contact vibration measurement: the laser speckle stroboscope. Non-contact vibration measurement always yields superior results compared to contact methods as it does not impose any sensor load on the system, making it crucial for sensitive systems. Non-contact measurement techniques are also employed to assess vibrations in extreme temperature and chemical environments where conventional sensors are prone to damage. This system, built with a laser, lenses, and a photodiode, offers significant improvements in precision compared to traditional stroboscopes. Conventional stroboscopes struggle to accurately measure linear vibrations, while high-precision alternatives like Laser Doppler Vibrometers (LDVs), are expensive. This study attempts to address the limitations associated with laser vibrometers. The laser speckle stroboscope addresses these limitations with a compact and cost-effective design. The system works by creating a laser-generated speckle pattern on the vibrating surface. This pattern is then sampled using a stroboscopic method in which the sampling period is synchronized with the vibration frequency. Rigorous testing confirmed the system's effectiveness. Focused laser beam precisely captured the rotational movements. For linear vibrations, the system detected deviations as low as 3 Hz for specific frequencies. The rotational measurements showed a maximum deviation of 2 Hz for two out of four tested speeds. These results were validated using an external laser vibrometer, proving the system's reliability.

Keywords: Laser speckle, Stroboscopic sampling, Vibration measurement.

### Nomenclature

$s(t)$	- Continuous signal	$k$	- The k-th signal frequency multiple
$T_s$	- Sampling period	$\delta$	- A value that differs very little from any multiple of the signal frequency
$T_v$	- Signal period	$\phi_n$	- Phase of data point "n"
$s[n]$	- Sampled signal	$e[n]$	- Difference in amplitude between two consecutive data points
$n$	- Number of samples	$z^{-1}$	- Unit delay

### 1. Introduction

Mechanical vibrations, which are an inherent aspect of life, can pose challenges for engineering systems. Prolonged operational lifespans are expected for engineering structures. However, structural vibrations can jeopardize this longevity, [1-2]. Therefore, the monitoring of vibrations is imperative on a continuous basis. The conventional vibration monitoring method is the contact-based approach. Within this methodology, resistive strain gages, piezoelectric transducers, and electromechanical transducers based on inductive operating principles are used. In addition, accelerometers and *Linear Variable Differential Transformers* (LVDTs) are commonly employed in contact-based vibration measurements. However, contact-based measurement approaches are not always optimal for every system.

Measurements conducted by contact sensors will not yield accurate results when the dynamics of the sensor interfere with the dynamics of the object being measured for vibration. For instance, the vibrations of a diaphragm in a microphone, a nanomaterial, or a hot spot on a jet engine reaching temperatures of up to 1000° cannot be accurately measured using conventional contact sensors. Although performing vibration calculations using software may seem cost-effective and straightforward, attaining accurate boundary conditions is challenging. Therefore, the requirement for experimental systems arises [3]. To meet this need, noncontact vibration measurement methods have been developed. Interferometers have become popular not only for precise displacement measurements but also for noncontact vibration measurements, [4-5]. Among these methods, many are optical, with *Laser Doppler Vibrometers* (LDVs) being prominent. Although cost-effective methods based on light intensity have been proposed [6], their precision is not as high as that of LDVs. Comprehensive studies on the development and applications of LDVs are available in the literature [7]. Since their initial introduction [8], LDVs have taken the lead in non-contact vibration measurements. When light impinges on a moving surface, a shift in the frequency of light occurs due to the velocity of the surface. LDVs were developed based on the principle of detecting this Doppler-frequency shift. However, in this method, alignment is crucial, and the formation of speckles on the surface where the light beam falls, which arises from surface roughness, significantly affects the measurement accuracy [9]. The effects of speckles on the erroneous outcomes of laser vibrometers have also been examined [10-11]. It has been suggested that spurious signals resulting from bending motion can be mitigated by increasing the speckle size on the detector plane [10]. Furthermore, a study proposing a statistical approach to enhance measurements indicated that speckle introduce noise in LDV measurements [11]. In studies employing LDV, speckle noise, a limited measurement range due to wavelength restrictions, and cost were identified as the primary drawbacks of these systems.

Since its inception in 1832, strobe lights have been used to determine the velocities of periodically moving objects. Stroboscopy gained popularity through Edgerton's use of stroboscopic light for photographing high-speed objects [12]. With the aid of a developed laser resonator architecture, a laser version of the classical Harold Edgerton strobe was introduced to overcome laser speckle issues [13]. It has been noted that the use of inexpensive lasers in this context adversely affects precise vibration measurements. Stroboscopic holography has been used to map the vibration of a surface [14]. In addition to the advantages it offers, this technique lags behind similar methods due to its complex implementation. Stroboscopic illumination is not necessary when using holography for vibration measurements. The measurement of vibrations with unknown frequencies and phases was achieved using a time-averaged digital holography technique [15]. It should be noted that the measurement accuracy of the initial phase of the vibration in this technique may not be very accurate. In a study employing a combination of stroboscope, camera, and Doppler radar, vibration measurement was successfully accomplished [16]. However, synchronization problems between the vibration and stroboscopic light can lead to measurement errors. *Visible Light Communication* (VLC) is a communication method that emerged alongside the popularity of LED-based illumination. Within the VLC approach, visible light is employed as a stroboscope to propose a non-contact vibration measurement method that enables measurements without interruption of communication [17]. Thus, measurements can be obtained without disrupting the communication link. The method used in VLC can be applied to vibration measurements using laser speckle, which is also the subject of this study. Using the stroboscopic layered light projection method (Structured Light Projection), it has been demonstrated that a structure's vibrations and amplitudes can be mapped from a few millimeters to several meters [18].

Since the nature and underlying mathematics of speckle formation in interferometric measurements have been elucidated, speckles have begun to be employed as a method for strain

and stress measurements [19]. Using a Laser Speckle Interferometer in conjunction with a long-distance microscope, vibration analysis of a surface illuminated by a stroboscopic lighting system has been successfully conducted [20-21]. The detailed dynamics of the microstructures were obtained through an interferometric measurement system. This system employs a laser diode-powered stroboscope to measure the vibrations of *micro-electro-mechanical systems* (MEMS) using laser speckle interference [22]. In studies combining stroboscopy with speckle interferometry, it has been stated that synchronization with the stroboscopic light source negatively affects measurement accuracy.

In most studies based on stroboscopic vibration measurements, the motion freeze phenomenon under the stroboscopic effect has been used. This effect can be achieved by sampling an electronic signal at specific time intervals, even without any light source. Employing stroboscopic sampling instead of classical sampling in radar signals achieved improved detection performance [23].

In this study, a novel vibration measurement method was introduced and validated using laser speckle interference and stroboscopic sampling techniques for the first time. Unlike traditional stroboscopic illumination, the proposed method employs diode laser technology. The speckles reflected from the surface illuminated by the laser are detected by a photodetector and converted into analog signals. By employing the stroboscopic sampling technique, analog signals are scanned, and measurements are performed by identifying points where the vibration frequency aligns with the stroboscopic sampling frequency. The proposed method was tested and verified in an experimental setup. Although it is true that the frequency can also be calculated by taking the *Fast Fourier Transform* (FFT) of the speckles, when the amplitudes are substantial, the spectrum may become cluttered with numerous harmonics. Particularly in rotational movements, the presence of multiple harmonics can make it difficult to accurately discern the actual frequency value. However, in contrast, this newly developed method uniquely uses speckles to derive a single and precise frequency value. The development of a stroboscope that can measure vibration and rotational motion frequencies eliminates the constraint of amplitude limitations. The equipment used consisted of a laser, two lenses, and a photodiode. A system capable of performing vibration measurements with such precision using this configuration has not yet been introduced in the literature. Moreover, this characteristic has transformed the system into a more compact and cost-effective one compared to existing systems, which is also absent in the current literature. By nature, the proposed system falls between high-cost *Laser Doppler Vibrometers* (LDVs) and low-cost classical stroboscopes. Another contribution of the proposed system to the literature is its capability to measure rotational movements that cannot be measured by classical stroboscopes due to the focusability of the laser beam. The proposed speckle-based system avoids speckle-related issues that impact LDVs. With this method, successful results can be achieved with inexpensive laser diodes and simple implementation, making the cost more favorable than those of other systems. In this method, synchronization issues are also avoided because no additional stroboscopic light source is used.

## 2. Method

### 2.1. Stroboscopic sampling theory

Given the importance of power consumption and cost in radar technologies, alternatives to high-speed AC-DC converters have been explored. In this context, the stroboscopic sampling method has been proposed as an alternative [23-24]. *Stroboscopic signal sampling* (SSS) is a technique used in radar target detectors, range finders, and other applications [25]. The SSS method allows for the analysis of fast-moving objects by periodically sampling the signal at

specific points in time. The SSS method is particularly useful for high-frequency signals, enabling the observation of rapid changes with high precision. In radar systems, stroboscopic sampling facilitates the detection and tracking of targets, providing detailed insights into their position, velocity, and dynamic characteristics. Similarly, in distance measurement devices like LIDAR systems, it enhances the measurement accuracy, particularly in *time-of-flight* (TOF) systems. The core principle involves sampling the signal at harmonics of the target signal's frequency, ensuring detailed temporal analysis. The SSS method analyzes rotating radar signals by sampling data at lower frequencies instead of traditional sampling. It extends the target detection time by acquiring fewer samples for each pulse, thus mitigating the need for high-speed sampling.

## 2.2. Generation of speckles

In the case of monochromatic parallel light rays reflected from a rough surface, a phase difference arises because of the path difference caused by the roughness of the surface. Each surface irregularity acts as a new light source according to the Huygens principle, leading to interactions among themselves and resulting in interference between the light waves. Constructive and destructive interferences can occur depending on the degree of phase difference. However, these interference patterns are not uniformly distributed due to the random nature of surface roughness, which determines the phase difference. When this interference pattern is projected onto a screen using a converging lens or an aperture, bright spots indicate points of constructive interference, while dark spots represent points of destructive interference, as shown in Fig. 1. These points on the screen are called speckles. Various approaches have been proposed to determine the size of speckles [26, 27].

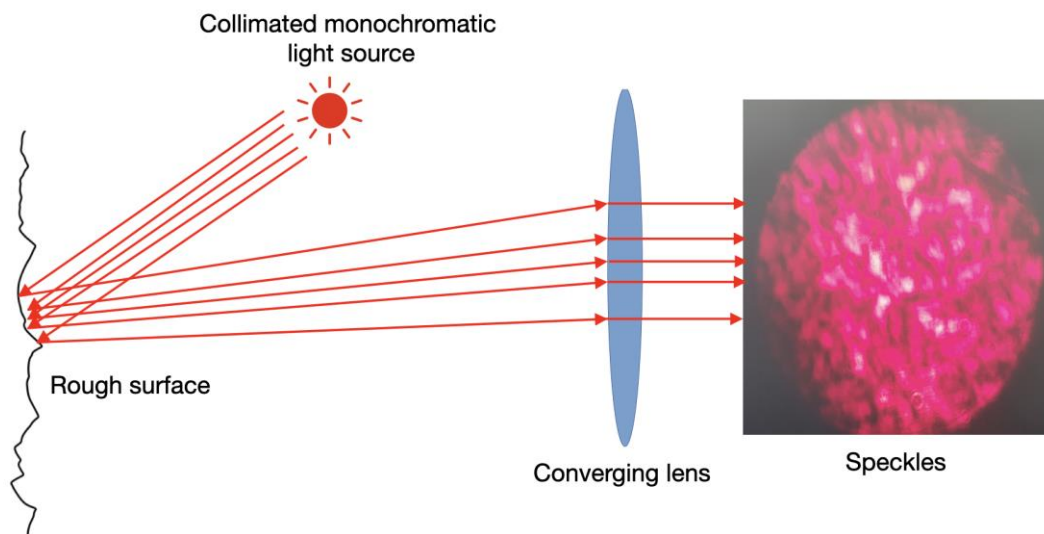

Fig. 1. Schematic of speckle formation.

## 2.3. Developed method

When monochromatic light is reflected from a surface that is in motion, the speckle patterns that fall on the screen change with motion. The proposed method captures this motion in a manner similar to the operation of a classic stroboscope. In a classic stroboscope, when the

frequency of the emitted light matches the frequency of the rotating object, motion freezing is induced. This allows determination of the angular velocity or frequency of an object.

In the proposed method, a monochromatic and parallel beam of light is directed toward the target, causing speckle formation on the rough surface. The resulting speckles are directed onto a phototransistor detector through a converging lens. The data obtained from the detector are scanned from a starting sampling frequency of zero to a predetermined upper limit. At each frequency value, at least two data points were acquired and analyzed. When the theoretical difference between these two data points is zero, similar to the classic stroboscope approach, the speckle is in the same position as the previous speckle. This gives the illusion of motion freezing, indicating that the movement has ceased. Figure 2 provides a representative visual illustration of the proposed method.

The laser used in this study was a standard pointer laser diode with a power of 5 mW, (Fig. 2c) . The wavelength is 650 nm, and its focal length can be adjusted using a convex lens (Fig. 2b). A TEMT6000 phototransistor system was used as the detector (Fig. 2e). It can measure 650-nm light sources with 90% sensitivity.

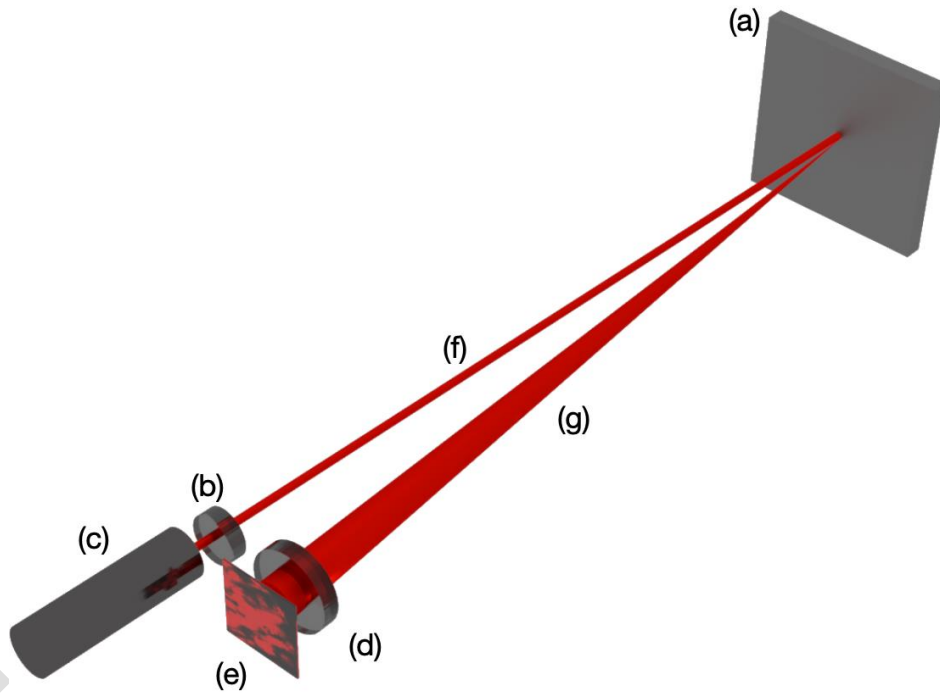

Fig. 2. Illustration of proposed method. A collimated and monochromatic light beam (c) emerges from the source, passes through a converging lens (b), and reaches a vibrating or rotating object (a). The speckles formed on the object's surface are predominantly scattered in the direction of the incident beam (g). The speckle reflections pass through the converging lens once again (d) and are projected onto the screen (e) where the detector is located. Thus, speckle detection is achieved.

In Fig. 3a, a signal sampled with a stroboscopic sampling period of  $T_s$  is shown. Let's assume that the signal is chosen as a periodic function according to the shape in (1)

$$s(t) = \left| \sin \left( 2\pi \frac{1}{T_v} t \right) \right| \quad (1)$$

Here,  $T_v$  represents the signal period. An expression for the signal sampled with  $T_s$  can be expressed as follows

$$s[n] = \left| \sin \left( 2\pi \frac{1}{T_v} (nT_s) \right) \right|, n \in \mathbb{Z} \quad (2)$$

Here,  $n$  represents the sampled data number. The difference in amplitude between two consecutive data points is given in (3).

$$e[n] = s[n] - s[n - 1] \quad (3)$$

By substituting the signal function from (2) for each  $n$  and  $n - 1$  value in the equation given in (3), (4) is obtained

$$e[n] = \left| \sin \left( 2\pi \frac{1}{T_v} (nT_s) \right) \right| - \left| \sin \left( 2\pi \frac{1}{T_v} ((n - 1)T_s) \right) \right| \quad (4)$$

When the sampling frequency,  $T_s$ , is a multiple of the signal period,  $T_v$ , all consecutive amplitude differences should be zero, as shown in Fig. 3-b. Mathematically, when  $T_s$  is equal to multiples of  $T_v$ , the error given in (4) will be zero, as stated in (5).

$$\lim_{T_s \rightarrow k.T_v} e[n] = |\sin(2\pi kn)| - |\sin(2\pi k(n - 1))| = 0 \quad (5)$$

According to this deduction, because of multiple points of zero error in a periodic signal using stroboscopic sampling, it is not possible to determine at which multiple signal frequencies are relative to the sampling frequency. However, the above theoretical expression holds for perfectly sampled signals. In real signals, there is always some level of noise or sampling error.

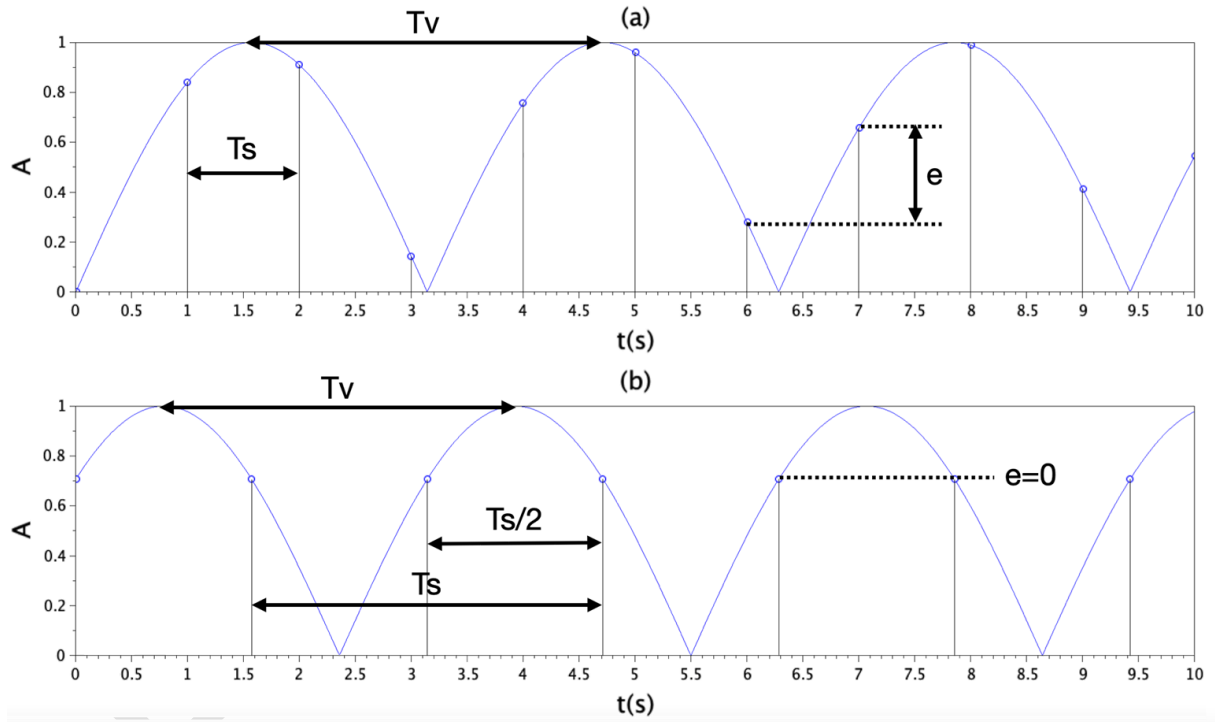

Fig. 3. Sampling of signals from speckles using the stroboscopic sampling method.

**Definition** (Flawed Periodic Signal): A signal that is sampled at multiples of its signal period and has a non-zero amplitude difference between consecutive data points is referred to as a flawed periodic signal.

According to the Definition, for flawed periodic signals, the expression (5) cannot be equal to zero.

$$\lim_{T_s \rightarrow k.T_v} e[n] \neq 0 \quad (6)$$

We can use the term "Flawed Periodic Signal" for almost any type of signal obtained from an analog channel in a real system.

**Hypothesis:** In flawed signals, even if error signal (5) is not equal to zero, the error value in a set of "n" sampled signals will be minimized.

**Proof:** Let the sampling period be  $\delta$  times different from any multiple of the vibration period for very small values of  $\delta$ . In this case, the limit given in expression (5) becomes as follows.

$$\lim_{T_s \rightarrow k \cdot T + \delta} e[n] = |\sin(2\pi kn + \phi_n)| - |\sin(2\pi k(n-1) + \phi_{n-1})| \quad (7)$$

the phase differences between two data points are denoted as  $\phi_n = 2\pi n \frac{\delta}{T_v}$  and  $\phi_{n-1} = 2\pi(n-1) \frac{\delta}{T_v}$ . As the sampling frequency,  $T_s$ , approaches  $\delta$  times any multiple of the vibration frequency,  $T_v$ , the phase differences between consecutive data points tend to zero, as indicated in (8-9).

$$\delta \approx 0 \rightarrow \phi_n = 2\pi n \frac{\delta}{T_v} \approx 0 \quad (8)$$

$$\delta \approx 0 \rightarrow \phi_{n-1} = 2\pi(n-1) \frac{\delta}{T_v} \approx 0 \quad (9)$$

Therefore, the limit value given in (7) also approaches zero, which means that it is minimized.

$$\delta \approx 0 \rightarrow \lim_{T_s \rightarrow k \cdot T_v + \delta} e[n] = |\sin(2\pi kn + \phi_n)| - |\sin(2\pi k(n-1) + \phi_{n-1})| \approx 0 \quad (10)$$

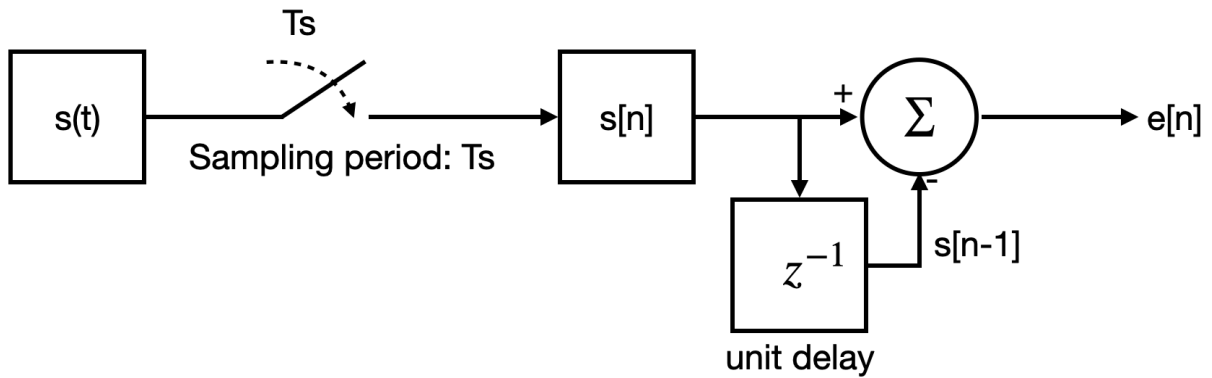

Fig. 4. Blockdiagram of proposed method. The signal "s(t)" is initially sampled with a period of "Ts". The error signal "e[n]" is obtained by subtracting the value of the sampled signal "s[n]" from its value in the previous period and recording it. In the next cycle, the same operations are continued by reducing the sampling period "Ts". The value of "e[n]" closest to zero corresponds to the period when the vibration period matches the sampling period.

This proposition is demonstrated through the experimental setup and experiments presented in Fig. 5.

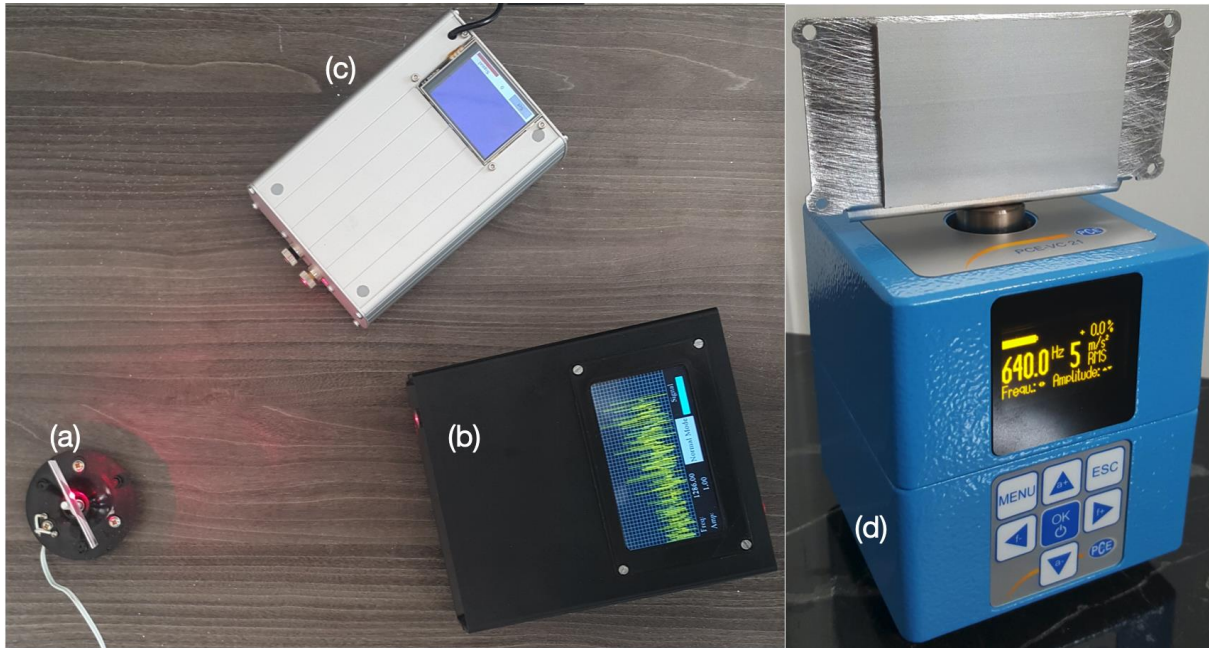

Fig. 5. Experimental Setup: a) Shaker; b) Laser Vibrometer; c) Developed Stroboscope; d) Vibration Calibration Device

#### 2.4. Experimental setup

The experimental validation of the proposition in this study was conducted using the experimental setup presented in Fig. 5. Within the experimental setup, linear vibration was obtained using a shaker generated from a loudspeaker (Fig. 5a). The signals are directed to the shaker via an amplifier from the computer's loudspeaker output using sinusoidal signal generator software. For rotational motion, an adjustable DC motor connected to a variable DC power supply was employed. The frequencies of the shaker and DC motor were verified using a Zienics laser vibrometer (Fig. 5b). The measurements were performed simultaneously using the developed stroboscope system (Fig. 5c). The stroboscope system depicted in Fig. 5c operates similarly to the schematic system presented in Fig. 2. A 12-bit AC/DC converter converts the signals acquired from the sensor into analog signals. The algorithm yielding the error signals shown in the hypothesis verification is executed in a microcontroller that performs AC/DC conversion, and the outcomes are conveyed to both the stroboscope LCD screen and the user's computer via a cable.

The experimental setup yielded a total of eight measurements consisting of four rotational and four linear measurements. The measurements were validated using a laser vibrometer. Due to the limitations of the DC motor utilized in the rotational measurements, the measurements were conducted at speeds of 34 Hz (2040 rpm), 50 Hz (3000 rpm), 60 Hz (3600 rpm), and 76 Hz (4560 rpm). In the case of linear vibrations, the shaker's wider bandwidth allowed measurements at frequencies of 20, 100, 400, and 800 Hz.

To enhance the test reliability, the proposed system was evaluated using the PCE Instruments PCE-VC 21 vibration calibration device (Fig. 5d). The calibration device employed during testing used test frequencies of 15.92, 40, 80, 159.2, 320, and 640 Hz.



### 3. Results

The results of the rotational measurements are presented in Fig. 6. As hypothesized, in flawed periodic signals, as the sampling frequency approaches multiples of the system's true frequency, the error signal reaches smaller values than the average. At the system's true frequency, due to (8-9), the phase difference is completely eliminated, causing the width of the trough created by the error signal to be broader than other true frequency multiples. The true frequency information of the system can be inferred from the frequency of the widest trough, where the error is minimized.

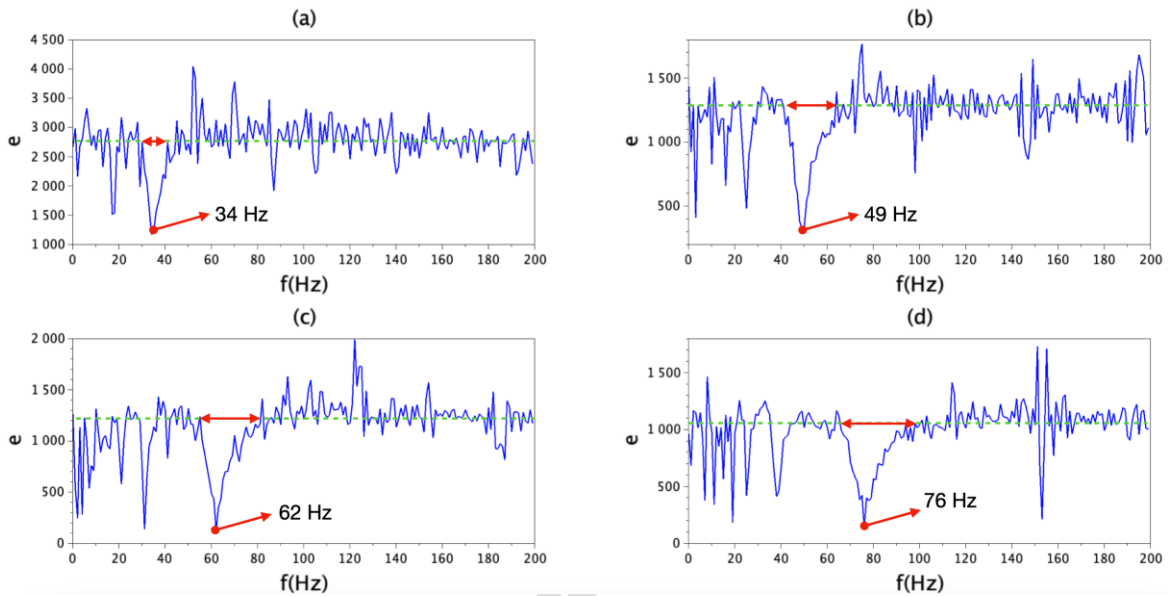

Fig. 6. Results of the rotational measurements. The green dashed line represents the average error, and the red arrow indicates the largest deviation from the average error. The horizontal axis denotes the sampling frequency, and the vertical axis represents the error signal given by (4). According to the values measured with the laser vibrometer; a) 34 Hz (2040 rpm) b) 50 Hz (3000 rpm) c) 60 Hz (3600 rpm) d) 76 Hz (4560 rpm).

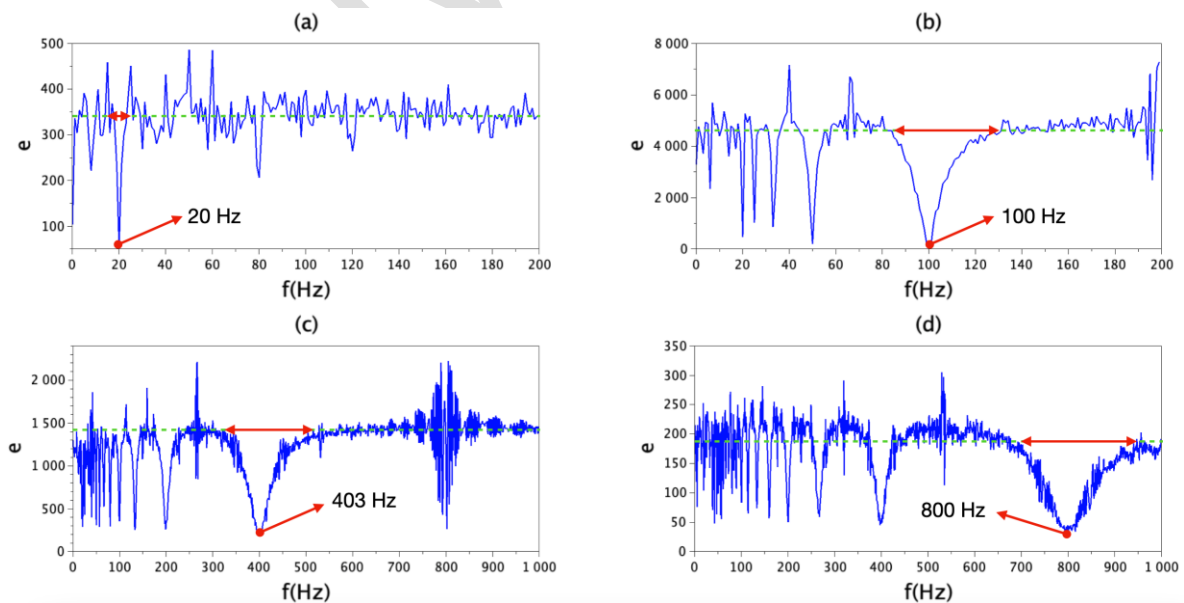

Fig. 7. Results of the linear measurements. According to the laser vibrometer data, the true frequency values were measured as follows: a) 20 Hz, b) 100 Hz, c) 400 Hz, and d) 800 Hz.

Results of the linear measurements are presented in Fig. 7. The graphs in Figs 7a and 7b are plotted in the range of 0-200 Hz to facilitate better readability of the frequency values. However, the measurements for linear vibration were taken in the range of 0-1000 Hz. Similar to rotational motion, the frequency of the widest trough, where the error is minimized, also corresponds to the vibration frequency.

The results of the tests performed with the calibration device are presented in Fig. 8. The graphs in Figs 8a, 8b, and 8c are also plotted in the range of 0-200 Hz to facilitate better readability of the frequency values. The maximum measurement error was 2 Hz (Fig. 8e), which is consistent with the results of the other tests.

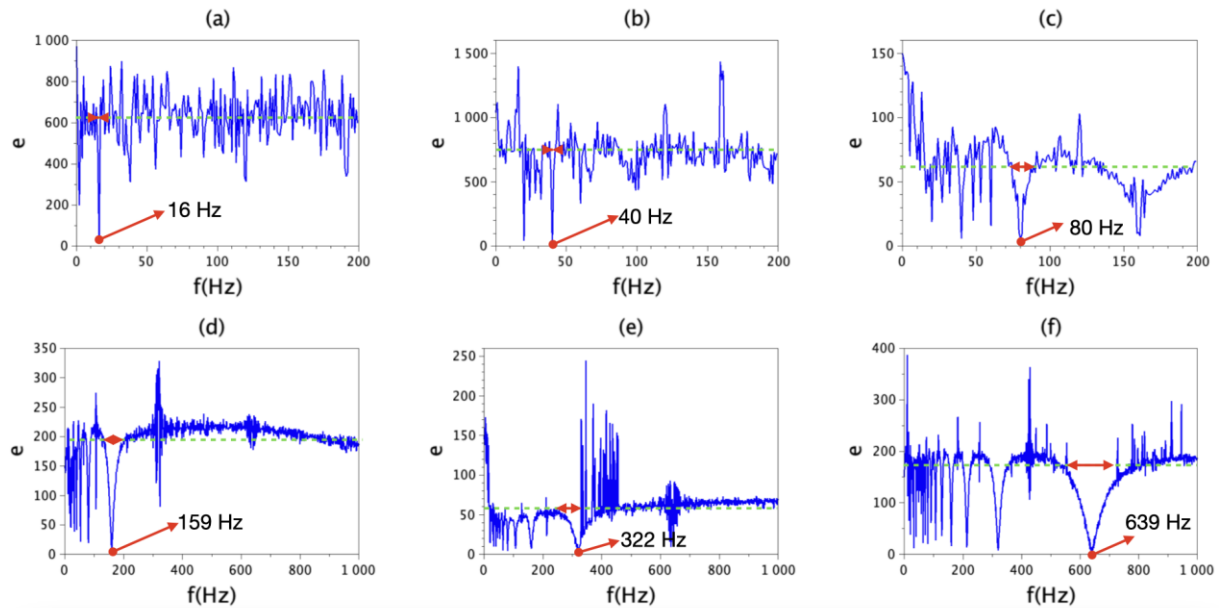

Fig. 8. Results of linear measurements with calibration device. According to the calibration device data, the true frequency values were measured as follows: a) 15.92 Hz, b) 40 Hz, c) 80 Hz, d) 159.2 Hz, e) 320 Hz, and f) 640 Hz.

#### 4. Discussion

In a system represented schematically in Fig. 2, the first method that comes to mind for measuring the frequency of a target object from speckles is the Fourier transform. However, when the amplitude is larger than the speckle, harmonics emerge, and it becomes uncertain which harmonic represents the true frequency. In the classical stroboscopic sampling method, working at multiples of the operational frequency in a smooth periodic signal has been observed to nullify the "e" value in the expression given in (4). This implies the presence of multiple harmonics. However, according to the experimental results, when the sampling frequency approaches the true vibration frequency, the error at all sampled points tends to minimize. Thus, the error troughs shown in Figs 6 and 7 are widest when the sampling frequency only approximates the measured frequency. Upon examining the graphs, it can be observed that, as stated in the hypothesis, the error values reach a minimum at multiples of the operational frequency. However, the true frequency corresponds to the frequency of the widest of these minimum troughs.

This study represents the first study to combine classical stroboscopic logic with the laser speckle method via stroboscopic sampling. Although the sole use of the laser speckle method did not yield a single speed or frequency value, this achievement was realized through the

proposed method. The proposed system avoids the use of complex optical and mechanical components. Thus, a cost-effective optical vibration measurement method has been introduced.

The proposed method offers the following advantages:

- Ease of Implementation, Durability, and Low Cost: Due to its simple design, the method is not only easy to implement but also inherently promotes durability and facilitates low-cost measurements.
- Speckle-based measurement: This method uses speckle patterns for measurements, eliminating the need for additional speckle filters or prevention mechanisms.
- Alignment Insensitivity: Speckle patterns can be observed from wide angles, eliminating alignment issues.
- Low Power Consumption: The absence of moving parts and gas lasers minimizes the power consumption.

The proposed method also has a few limitations:

- Incapability of Linear Vibration Amplitude Calculation: This method cannot directly calculate the linear vibration amplitude during linear vibration measurements.
- Extended Measurement Time: The sequential scanning of the frequency range results in a measurement time of approximately 5 min per measurement, which limits its suitability for real-time applications.

## 5. Conclusions

The outcomes of this research can be summarized as follows:

1. The stroboscopic sampling method, when applied to a signal, theoretically minimizes the change in the sampled signal when the signal frequency aligns with the sampling frequency. Equations (1-10) presented in this paper mathematically describe this phenomenon.
2. The proposed hypothesis was experimentally validated using the system introduced in Section 2.4, employing laser speckles reflected from rotating and vibrating objects.
3. The obtained results are presented as graphs in Figs 6, 7, and 8.

The obtained results not only provide experimental validation for the proposed hypothesis but also demonstrate the method's capability for non-contact, low-cost, and high-precision frequency measurement of objects.

## Acknowledgment

This study was supported within the scope of the Scientific Research Projects Coordination Office of Necmettin Erbakan University, under project number 23GAP19011.

## References

- [1] Hajnayeb, A., Shirazi, K. H., & Aghamiri, R. (2020). Vibration measurement for crack and rub detection in rotors. *Metrology and Measurement Systems*, 65-80. <https://doi.org/10.24425/mms.2020.131719>
- [2] Olejnik, A., Rogólski, R., & Szcześniak, M. (2021, June). Contact and non-contact methods of vibration measurement in aircraft structures. In *2021 IEEE 8th International Workshop on Metrology for AeroSpace (MetroAeroSpace)* (pp. 619-624). IEEE.
- [3] Lezhin, D. S., Falaleev, S. V., Safin, A. I., Ulanov, A. M., & Vergnano, D. (2017). Comparison of different methods of non-contact vibration measurement. *Procedia Engineering*, 176, 175-183. <https://doi.org/10.1016/j.proeng.2017.02.286>

- [4] Dobosz, M. (2012). Laser diode distance measuring interferometer-metrological properties. *Metrology and Measurement Systems*, 19(3), 553-564. <https://doi.org/10.2478/v10178-012-0048-1>
- [5] Johnson, S. J., Lualdi, C. P., Conrad, A. P., Arnold, N. T., Vayninger, M., & Kwiat, P. G. (2023, March). Toward vibration measurement via frequency-entangled two-photon interferometry. In *Quantum Sensing, Imaging, and Precision Metrology* (Vol. 12447, pp. 268-273). SPIE. <https://doi.org/10.1117/12.2650820>
- [6] Perrone, G., & Vallan, A. (2008). A low-cost optical sensor for noncontact vibration measurements. *IEEE Transactions on Instrumentation and Measurement*, 58(5), 1650-1656. <https://doi.org/10.1109/TIM.2008.2009144>
- [7] Rothberg, S. J., Allen, M. S., Castellini, P., Di Maio, D., Dirckx, J. J. J., Ewins, D. J., ... & Vignola, J. F. (2017). An international review of laser Doppler vibrometry: Making light work of vibration measurement. *Optics and Lasers in Engineering*, 99, 11-22. <https://doi.org/10.1016/j.optlaseng.2016.10.023>
- [8] Yeh, Y., & Cummins, H. Z. (1964). Localized fluid flow measurements with an He-Ne laser spectrometer. *Applied Physics Letters*, 4(10), 176-178. <https://doi.org/10.1063/1.1753925>
- [9] Dainty, J. C. (Ed.). (2013). *Laser speckle and related phenomena* (Vol. 9). Springer science & business Media.
- [10] McDevitt, T. E., & Vikram, C. S. (1997). An investigation of pseudovibration signals in dual beam laser vibrometry. *Review of Scientific Instruments*, 68(4), 1753-1755. <https://doi.org/10.1063/1.1147986>
- [11] Vass, J., Šmid, R., Randall, R. B., Sovka, P., Cristalli, C., & Torcianti, B. (2008). Avoidance of speckle noise in laser vibrometry by the use of kurtosis ratio: Application to mechanical fault diagnostics. *Mechanical Systems and Signal Processing*, 22(3), 647-671. <https://doi.org/10.1016/j.ymssp.2007.08.008>
- [12] Edgerton, H. E., Hauser, E. A., & Tucker, W. B. (1937). Studies in drop formation as revealed by the high-speed motion camera. *Journal of Physical Chemistry*, 41(7), 1017-1028. <https://doi.org/10.1021/j150385a012>
- [13] Steinforth, A. W., Rivera, J. A., & Eden, J. G. (2022). Imaging of transient phenomena with low coherence lasers comprising arrays of independent microbeams: A laser version of Harold Edgerton's stroboscope. *APL Photonics*, 7(1). <https://doi.org/10.1063/5.0076899>
- [14] Verpillat, F., Joud, F., Atlan, M., & Gross, M. (2012). Imaging velocities of a vibrating object by stroboscopic sideband holography. *Optics Express*, 20(20), 22860-22871. <https://doi.org/10.1364/OE.20.022860>
- [15] Stipčević, M., Demoli, N., Skenderović, H., Lončarić, M., Radman, A., Gladić, J., & Lovrić, D. (2017). Effective procedure for determination of unknown vibration frequency and phase using time-averaged digital holography. *Optics Express*, 25(9), 10241-10254. <https://doi.org/10.1364/OE.25.010241>
- [16] Roy, D., Misra, P., Chakravarty, T., Sinharay, A., Rakshit, R., & Pal, A. (2019). A novel unobtrusive vibration sensing system for machine inspection. *Modern Sensing Technologies*, 349-365. [https://doi.org/10.1007/978-3-319-99540-3\\_18](https://doi.org/10.1007/978-3-319-99540-3_18)
- [17] Amjad, M. S., & Dressler, F. (2020, June). Integrated communications and non-invasive vibrations sensing using strobing light. In *ICC 2020-2020 IEEE International Conference on Communications (ICC)* (pp. 1-6). IEEE. <https://doi.org/10.1109/ICC40277.2020.9148637>
- [18] Ribeiro, I. L. F., Carvalho, G. L., Dib, L. F. G., Barbosa, E. A., & Wetter, N. U. (2023). Vibration amplitude mapping by stroboscopic structured light projection. *Optics Communications*, 531, 129219. <https://doi.org/10.1016/j.optcom.2022.129219>
- [19] Yang, L., & Colbourne, P. (2003). Digital laser micointerferometer and its applications. *Optical Engineering*, 42(5), 1417-1426. <https://doi.org/10.1117/1.1564103>
- [20] Yang, L. X., Schuth, M., Thomas, D., Wang, Y. H., & Voelsing, F. (2009). Stroboscopic digital speckle pattern interferometry for vibration analysis of microsystem. *Optics and Lasers in Engineering*, 47(2), 252-258. <https://doi.org/10.1016/j.optlaseng.2008.04.025>
- [21] Spagnolo, G. S., & Leccese, F. (2023, June). Local Correlation Degree of Laser Speckle for Vibration Analysis. In *2023 IEEE 10th International Workshop on Metrology for AeroSpace (MetroAeroSpace)* (pp. 655-660). IEEE. <https://doi.org/10.1109/MetroAeroSpace57412.2023.10190005>
- [22] Hart, M. R., Conant, R. A., Lau, K. Y., & Muller, R. S. (2000). Stroboscopic interferometer system for dynamic MEMS characterization. *Journal of Microelectromechanical Systems*, 9(4), 409-418. <https://doi.org/10.1109/84.896761>

- [23] Bystrov, A., & Gashinova, M. (2013). Analysis of stroboscopic signal sampling for radar target detectors and range finders. *IET Radar, Sonar & Navigation*, 7(4), 451-458. <https://doi.org/10.1049/iet-rsn.2012.0272>
- [24] Howard, D. D. (1975). High range-resolution monopulse tracking radar. *IEEE Transactions on Aerospace and Electronic Systems*, AES-1(5), 749-755. <https://doi.org/10.1109/TAES.1975.307984>
- [25] Bystrov, A. N. (2011). Range finder with stroboscopic signal sampling based on 'Multicore. DSP family'. *Problems of Radio Electronics*, 1, 107-114.
- [26] Sjö Dahl, M., & Benckert, L. R. (1994). Systematic and random errors in electronic speckle photography. *Applied Optics*, 33(31), 7461-7471. <https://doi.org/10.1364/AO.33.007461>
- [27] Zdunek, A., Muravsky, L. I., Frankevych, L., & Konstankiewicz, K. (2007). New nondestructive method based on spatial-temporal speckle correlation technique for evaluation of apples quality during shelf-life. *International Agrophysics*, 21(3), 305-310.



**İbrahim Yıldız** completed his undergraduate education in 2004 at Istanbul University, Faculty of Engineering, Department of Mechanical Engineering. He obtained his master's degree in "Mechanical Theory and Control" in 2007 from Yıldız Technical University Institute of Science and Technology, where he also completed his PhD in 2011. His doctoral thesis focused on the control of spatially

moving vehicles using the Stewart platform mechanism.

Between 2005 and 2013, Yıldız worked as a Research Assistant at Yıldız Technical University, and in 2013, he joined the Department of Mechatronics Engineering at Necmettin Erbakan University as an Assistant Professor. Throughout his academic career, he has been involved in various projects, published articles in national and international journals, presented at scientific conferences, and supervised master's theses.

He is currently a Associate Professor and the Mechatronics Engineering Department in the Necmettin Erbakan University, Türkiye.